

Everything's possible.

Analog Drives
for Servo Systems

Hardware
Installation Manual



Preface

ADVANCED Motion Controls constantly strives to improve all of its products. We review the information in this document regularly and we welcome any suggestions for improvement. We reserve the right to modify equipment and documentation without prior notice.

For the most recent software, the latest revisions of this manual, and copies of compliance and declarations of conformity, visit the company's website at www.a-m-c.com. Otherwise, contact the company directly at:

ADVANCED Motion Controls • 3805 Calle Tecate Camarillo, CA • 93012-5068 USA

Agency Compliances

The company holds original documents for the following:

- UL 508c, file number E140173
- Electromagnetic Compatibility, EMC Directive - 2004/108/EC
EN61000-6-2:2005
EN61000-6-4:2007
- Electrical Safety, Low Voltage Directive - 2006/95/EC
EN 60204-1:2006
- Reduction of Hazardous Substances (RoHS), 2011/65/EU

Trademarks

ADVANCED Motion Controls™, the combined isosceles trapezoid/right triangle logo, **DIGIFLEX®**, **DIGIFLEX® Performance™** and DriveWare™ are either registered trademarks or trademarks of *ADVANCED* Motion Controls in the United States and/or other countries. All other trademarks are the property of their respective owners.

Related Documentation

- Product datasheet specific for your drive, available for download at www.a-m-c.com.

Attention Symbols

The following symbols are used throughout this document to draw attention to important operating information, special instructions, and cautionary warnings. The section below outlines the overall directive of each symbol and what type of information the accompanying text is relaying.



Note

Note - Pertinent information that clarifies a process, operation, or ease-of-use preparations regarding the product.



Notice

Notice - Required instruction necessary to ensure successful completion of a task or procedure.



Caution

Caution - Instructs and directs you to avoid damaging equipment.



Warning

Warning - Instructs and directs you to avoid harming yourself.



DANGER

Danger - Presents information you must heed to avoid serious injury or death.

Revision History

Document ID	Revision #	Date	Changes
MNALHWIN-01	1	9/25/2009	Analog Product Family Hardware Installation Manual First Release
MNALHWIN-02	2	5/13/2011	Discontinuation of B100A40, B100A40AC, B60A40, B60A40AC, B100A8, B100A20
MNALHWIN-03	3	5/30/2013	Addition of B060A400AC and B100A400AC
MNALHWIN-04	4	6/30/2013	Discontinuation of S60A8, S100A8, S100A40AC, SX30A8

© 2013 *ADVANCED* Motion Controls. All rights reserved.

1 Safety **1**

1.1 General Safety Overview	1
-----------------------------------	---

2 Products and System Requirements **4**

2.1 Analog Drive Family Overview	4
2.1.1 Products Covered	4
Drive Datasheet	4
Standard and Custom Models	5
2.2 Analog PWM Servo Drive Basics and Theory	6
2.2.1 Single Phase (Brushed) Servo Drives	7
2.2.2 Three Phase (Brushless) Servo Drives	7
2.3 Power Stage Specifications	9
2.4 Command Inputs	10
2.4.1 $\pm 10V$ Analog	10
2.4.2 PWM and Direction	10
2.4.3 Sinusoidal	10
2.5 Feedback Specifications	11
2.5.1 Feedback Polarity	11
2.5.2 Incremental Encoder	11
2.5.3 Hall Sensors	12
2.5.4 Tachometer	13
2.6 Modes of Operation	14
2.6.1 Current (Torque) Mode	14
2.6.2 Duty Cycle (Open Loop) Mode	14
2.6.3 Hall Velocity Mode	15
2.6.4 Encoder Velocity Mode	15

2.6.5 Tachometer Velocity Mode	15
2.6.6 Voltage Mode	16
2.6.7 IR Compensation Mode	16
2.6.8 Analog Position Loop Mode	16
2.7 System Requirements	17
2.7.1 Analog Servo Drive Selection and Sizing	17
Motor Current and Voltage	17
Motor Inductance	19
2.7.2 Power Supply Selection and Sizing	20
Power Supply Current and Voltage	20
Isolation	22
Regeneration and Shunt Regulators	23
Voltage Ripple	25
2.7.3 Environmental Specifications	26
Shock/Vibrations	26

3 Integration in the Servo System

27

3.1 LVD Requirements	27
3.2 CE-EMC Wiring Requirements	28
General	28
Analog Input Drives	28
PWM Input Drives	28
MOSFET Switching Drives	28
IGBT Switching Drives	28
Fitting of AC Power Filters	28
3.2.1 Ferrite Suppression Core Set-up	29
3.2.2 Inductive Filter Cards	29
3.3 Grounding	30
3.4 Wiring	31
3.4.1 Wire Gauge	31
3.4.2 Motor Wires	32
3.4.3 Power Supply Wires	32
DC Power Supplies	33
Single Phase AC Power Supplies	34
Three Phase AC Power Supplies	34
3.4.4 Feedback Wires	34
Hall Sensors	35
Incremental Encoder	35

Tachometer	36
3.4.5 Input Reference Wires	36
±10V Analog Input	36
Potentiometer Input	37
PWM and Direction Inputs	37
Sinusoidal Input	39
3.5 Mounting	39

4 Operation 40

4.1 Initial Setup and Features	40
4.1.1 Pin Function Details	40
Current Monitor Output	40
Current Reference Output	41
Inhibit Input	41
Continuous Current Limit Pin	41
Fault Output	42
Low Voltage Power Supply Outputs	42
Velocity Monitor Output	42
4.1.2 Potentiometer Function Details	43
Test Points for Potentiometers	43
4.1.3 Switch Function Details	44
4.1.4 Adjustable Acceleration and Deceleration Rate	44
4.1.5 Tachometer Input Gain Scaling	45
4.1.6 Current Limiting Procedure	46
4.1.7 Drive Set-up Instructions	47
Single Phase (Brush Type)	47
Three Phase (Brushless)	47
Three Phase (Brushless) Drive with Brushed Motor	48
Sinusoidal Drive (S-Series)	49
4.1.8 Tuning Procedure	49
Current Loop Proportional Gain Adjustment	50
Current Loop Integrator Adjustment	52
Voltage or Velocity Loop Tuning	52
Analog Position Loop	53

A Through-hole Component Tuning **54**

A.1 Through-Hole Tuning	54
A.1.1 Procedure	56
Tune the Current Loop Proportional Gain	56
Tune the Current Loop Integral Gain	56
Velocity Loop Integral Gain Tuning	57

B Troubleshooting **58**

B.1 Fault Conditions and Symptoms	58
Over-Temperature	58
Over-Voltage Shutdown	58
Under-Voltage Shutdown	59
Short Circuit Fault	59
Invalid Hall Sensor State (Brushless Drives only)	59
Inhibit Input	59
Power-On Reset	59
B.1.1 Overload	59
B.1.2 Current Limiting	60
Non-Foldback Current Limiting	61
B.1.3 Motor Problems	61
B.1.4 Causes of Erratic Operation	62
B.2 Technical Support	62
B.2.1 Product Label Description	62
B.2.2 Drive Model Information	63
B.3 Warranty Returns and Factory Help	63

Index I

1 Safety

This section discusses characteristics of your analog servo drive to raise your awareness of potential risks and hazards. The severity of consequences ranges from frustration of performance, through damage to equipment, injury or death. These consequences, of course, can be avoided by good design and proper installation into your mechanism.

1.1 General Safety Overview

In order to install an analog drive into a servo system, you must have a thorough knowledge and understanding of basic electronics, computers and mechanics as well as safety precautions and practices required when dealing with the possibility of high voltages or heavy, strong equipment.

Observe your facility's lock-out/tag-out procedures so that work can proceed without residual power stored in the system or unexpected movements by the machine.



Notice

You must install and operate motion control equipment so that you meet all applicable safety requirements. Ensure that you identify the relevant standards and comply with them. Failure to do so may result in damage to equipment and personal injury.

Read this entire manual prior to attempting to install or operate the drive. Become familiar with practices and procedures that allow you to operate these drives safely and effectively. You are responsible for determining the suitability of this product for the intended application. The manufacturer is neither responsible nor liable for indirect or consequential damages resulting from the inappropriate use of this product.



Notice

High-performance motion control equipment can move rapidly with very high forces. Unexpected motion may occur especially during product commissioning. Keep clear of any operational machinery and never touch them while they are working.

**Warning**

Keep clear of all exposed power terminals (motor, DC Bus, shunt, DC power, transformer) when power is applied to the equipment. Follow these safety guidelines:

- Always turn off the main power and allow sufficient time for complete discharge before making any connections to the drive.
- Do not rotate the motor shaft without power. The motor acts as a generator and will charge up the power supply capacitors through the drive. Excessive speeds may cause over-voltage breakdown in the power output stage. Note that a drive having an internal power converter that operates from the high voltage supply will become operative.
- Do not short the motor leads at high motor speeds. When the motor is shorted, its own generated voltage may produce a current flow as high as 10 times the drive current. The short itself may not damage the drive but may damage the motor. If the connection arcs or opens while the motor is spinning rapidly, this high voltage pulse flows back into the drive (due to stored energy in the motor inductance) and may damage the drive.
- Do not make any connections to any internal circuitry. Only connections to designated connectors are allowed.
- Do not make any connections to the drive while power is applied.

**Caution**

- Do not reverse the power supply leads! Severe damage will result!
- If using relays or other means to disconnect the motor leads, be sure the drive is disabled before reconnecting the motor leads to the drive. Connecting the motor leads to the drive while it is enabled can generate extremely high voltage spikes which will damage the drive.

**Caution**

Use sufficient capacitance!

Pulse Width Modulation (PWM) drives require a capacitor on the high voltage supply to store energy during the PWM switching process. Insufficient power supply capacitance causes problems particularly with high inductance motors. During braking much of the stored mechanical energy is fed back into the power supply and charges its output capacitor to a higher voltage. If the charge reaches the drive's over-voltage shutdown point, output current and braking will cease. At that time energy stored in the motor inductance continues to flow through diodes in the drive to further charge the power supply capacitance. The voltage rise depends upon the power supply capacitance, motor speed, and inductance.



Caution

Make sure minimum inductance requirements are met!

Pulse Width modulation (PWM) servo drives deliver a pulsed output that requires a minimum amount of load inductance to ensure that the DC motor current is properly filtered. The minimum inductance values for different drive types are shown in the individual data sheet specifications. If the drive is operated below its maximum rated voltage, the minimum load inductance requirement may be reduced. Most servo-motors have enough winding inductance. Some types of motors (e.g. "basket-wound", "pancake", etc.) do not have a conventional iron core rotor, so the winding inductance is usually less than 50 μ H.

If the motor inductance value is less than the minimum required for the selected drive, use an external filter card.

2 Products and System Requirements

This chapter is intended as a guide and general overview in selecting, installing, and operating an analog servo drive. Contained within are instructions on system integration, wiring, drive-setup, and standard operating methods.

2.1 Analog Drive Family Overview

The analog drive family contains drives that can power Single Phase (Brushed) and Three Phase (Brushless) motors. Analog drives are powered off either a single DC or AC power supply, and provide a variety of control and feedback options. The drives accept either a $\pm 10V$ analog signal, a PWM and Direction signal, or two sinusoidal command signals as input. A digital controller can be used to command and interact with analog servo drives, and a number of input/output pins are available for parameter observation and drive configuration.

2.1.1 Products Covered

The products covered in this manual adhere to the following part numbering structure. However, additional features and/or options are readily available for OEM's with sufficient ordering volume. Feel free to contact *ADVANCED* Motion Controls for further information.

FIGURE 2.1 Analog Product Family Part Numbering Structure

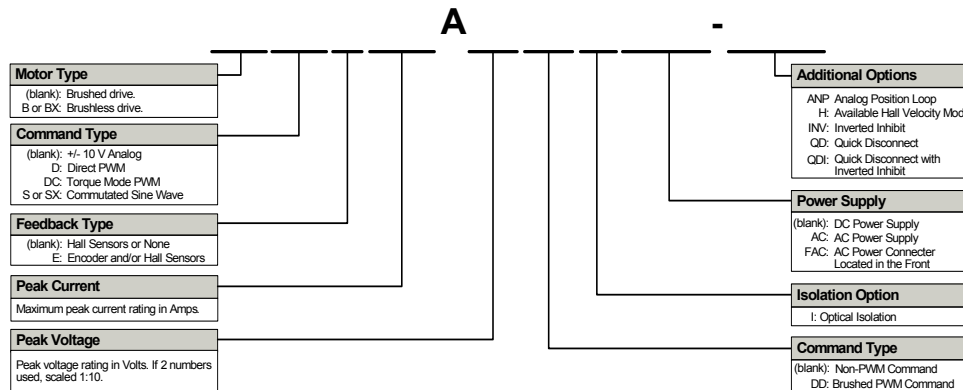

Drive Datasheet Each analog drive has a separate datasheet that contains important information on the modes and product-specific features available with that particular drive,

including the functional block diagram of the specific drive's operation. The datasheet is to be used in conjunction with this manual for system design and installation.

Standard and Custom Models The drives in the tables below are the standard product line of *ADVANCED* Motion Controls' analog servo drives. Note that not all possible part number combinations from the product family numbering structure (Figure 2.1) are offered as standard drives. Please contact *ADVANCED* Motion Controls' Sales Department for further information and details on custom drive solutions.

TABLE 2.1 Brushed $\pm 10V$ Analog DC Drives

Drive Number	VDC (Nominal)	Peak Current (A)	Cont. Current (A)
12A8	20-80	12	6
25A8	20-80	25	12.5
30A8	20-80	30	15
50A8	20-80	50	25
120A10	20-80	120	60
20A20	40-190	20	10
25A20I	40-190	25	12.5
50A20I	40-190	50	25
100A40	80-400	100	50

TABLE 2.2 Brushless $\pm 10V$ Analog DC Drives

Drive Number	VDC (Nominal)	Peak Current (A)	Cont. Current (A)
B15A8	20-80	15	7.5
BE15A8	20-80	15	7.5
BE15A8-H	20-80	15	7.5
B30A8	20-80	30	15
BE30A8	20-80	30	15
BX30A8	20-80	30	15
B25A20I	40-190	25	12.5
BE25A20I	40-190	25	12.5
BX25A20	60-200	25	12.5
B40A20I	40-190	40	20
BE40A20I	40-190	40	20
B30A40	60-400	30	15
B40A40	60-400	40	20

TABLE 2.3 Brushed $\pm 10V$ Analog AC Drives¹

Drive Number	VAC (Nominal)	Peak Current (A)	Cont. Current (A)
16A20AC	30-125	16	8
30A20AC	30-125	30	15

TABLE 2.4 Brushless $\pm 10V$ Analog AC Drives¹

Drive Number	VAC (Nominal)	Peak Current (A)	Cont. Current (A)
B25A20AC	30-125	25	12.5
BE25A20AC	30-125	25	12.5
BX25A20AC	45-125	25	12.5
B30A40AC	45-265	30	15
B40A40AC	45-265	40	20
B060A400AC	200-240	60	30
B100A400AC	200-240	100	50

TABLE 2.5 Brushed PWM Input DC Drives

Drive Number	VDC (Nominal)	Peak Current (A)	Cont. Current (A)
30A8DD	20-80	30	15
50A8DD	20-80	50	25
25A20DD	40-190	25	12.5
50A20DD	40-190	50	25

TABLE 2.6 Brushless PWM Input DC Drives

Drive Number	VDC (Nominal)	Peak Current (A)	Cont. Current (A)
BD15A8	20-80	15	7.5
BD30A8	20-80	30	15
BDC30A8	20-80	30	15
BD25A20	40-190	25	12.5
BD25A20I	40-190	25	12.5
BDC40A20	60-190	40	20

TABLE 2.7 Brushless PWM Input AC Drives¹

Drive Number	VAC (Nominal)	Peak Current (A)	Cont. Current (A)
BD25A20AC	30-125	25	12.5

TABLE 2.8 Sinusoidal Input DC Drives

Drive Number	VDC (Nominal)	Peak Current (A)	Cont. Current (A _{rms})
S16A8	20-80	16	8
SX25A20	60-190	25	12.5
S30A40	60-400	30	15
S60A40	60-400	60	30
S100A40	60-400	100	50

TABLE 2.9 Sinusoidal Input AC Supply Drives¹

Drive Number	VAC (Nominal)	Peak Current (A)	Cont. Current (A _{rms})
S30A40AC	45-265	30	15
S60A40AC	45-270	60	30

1. Certain AC drive models can also accept a DC power supply. Consult the drive datasheet to determine if DC input is allowed.

2.2 Analog PWM Servo Drive Basics and Theory

Analog servo drives are used extensively in motion control systems where precise control of position and/or velocity is required. The drive transmits the low-energy reference signals from the controller into high-energy signals (motor voltage and current). The reference signals can be either analog or digital, with a ± 10 VDC signal being the most common. The signal can represent either a motor torque or velocity demand.

Figure 2.2 shows the components typically used in a servo system (i.e. a feedback system used to control position, velocity, and/or acceleration). The controller contains the algorithms to close the desired servo loops and also handles machine interfacing (inputs/outputs, terminals, etc.). The drive represents the electronic power converter that drives the motor according to the controller reference signals. The motor (which can be of the brushed or brushless type, rotary, or linear) is the actual electromagnetic actuator, which generates the forces required to move the load. Feedback elements are mounted on the motor and/or load in order to close the servo loop.

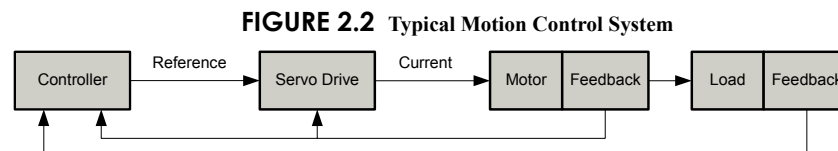

Although there exist many ways to "amplify" electrical signals, pulse width modulation (PWM) is by far the most efficient and cost-effective approach. At the basis of a PWM servo drive is a current control circuit that controls the output current by varying the duty cycle of the output power stage (fixed frequency, variable duty cycle). Figure 2.3 shows a typical setup for a single phase load.

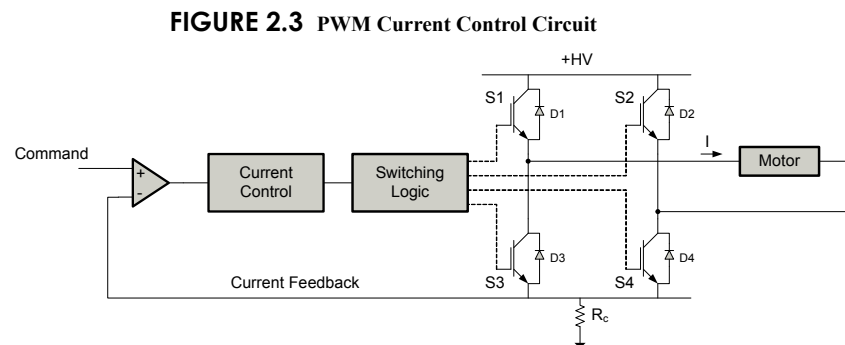

S1, S2, S3, and S4 are power devices (MOSFET or IGBT) that can be switched on or off. D1, D2, D3, and D4 are diodes that guarantee current continuity. The bus voltage is depicted by +HV. The resistor R_c is used to measure the actual output current. For electric motors, the load is typically inductive due to the windings used to generate electromagnetic fields. The current can be regulated in both directions by activating the appropriate switches. When switch S1 and S4 (or S2 and S3) are activated, current will flow in the positive (or negative) direction and increase. When switch S1 is off and switch S4 is on (or S2 off and S3 on) current will flow in the positive (or negative) direction and decrease (via one of the diodes). The switch "ON" time is determined by the difference between the current demand and the actual current. The

current control circuit will compare both signals every time interval (typically 50 μ sec or less) and activate the switches accordingly (this is done by the switching logic circuit, which also performs basic protection functions). Figure 2.4 shows the relationship between the pulse width (ON time) and the current pattern. The current rise time will depend on the bus voltage (+HV) and the load inductance. Therefore, certain minimum load inductance requirements are necessary depending on the bus voltage.

FIGURE 2.4 Output Current and Duty Cycle Relationship

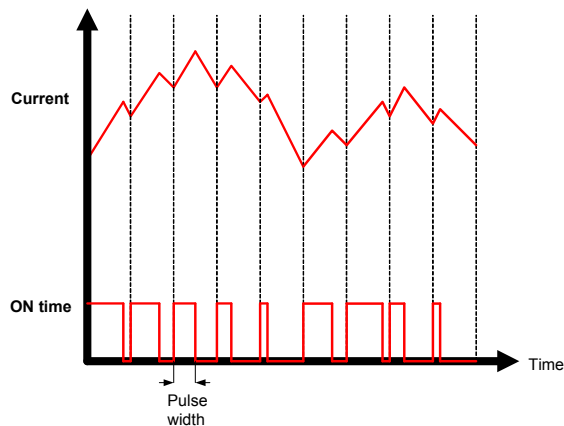

2.2.1 Single Phase (Brushed) Servo Drives

Brushed type servo drives are designed for use with permanent magnet brushed DC motors (PMDC motors). The drive construction is basically as shown in Figure 2.3. PMDC motors have a single winding (armature) on the rotor, and permanent magnets on the stator (no field winding). Brushes and commutators maintain the optimum torque angle. The torque generated by a PMDC motor is proportional to the current, giving it excellent dynamic control capabilities in motion control systems.

Brushed drives can also be used to control current in other inductive loads such as voice coil actuators, magnetic bearings, etc.

2.2.2 Three Phase (Brushless) Servo Drives

Three Phase (brushless) servo drives are used with brushless servo motors. These motors typically have a three-phase winding on the stator and permanent magnets on the rotor. Brushless motors require commutation feedback for proper operation (the commutators and brushes perform this function on brush type motors). This feedback consists of rotor magnetic field orientation information, supplied either by magnetic field sensors (Hall Effect sensors) or position sensors (encoder or resolver). Brushless motors have better power density ratings than brushed motors because heat is generated in the stator, resulting in a shorter thermal path to the outside environment. Figure 2.5 shows a typical system configuration.

FIGURE 2.5 Brushless Servo System

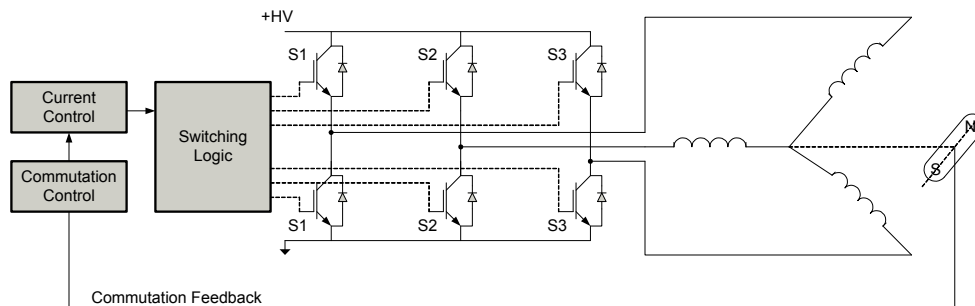

The commutation function can also be implemented in the motion controller, as in the case of *ADVANCED* Motion Controls sinusoidal command input drives. The drive merely amplifies the controller signals (2 analog sinusoidal signals that represent 2 of the 3 motor phase currents) and creates the third motor phase current (the sum of the 3 currents must be zero) and adjusts the phase angle to obtain maximum torque. No position feedback needs to be wired into the drive. The motor current amplitude is proportional to the reference signal amplitude, while the reference signal frequency depends on the motor velocity and the motor pole count.

FIGURE 2.6 Controller-based Commutation

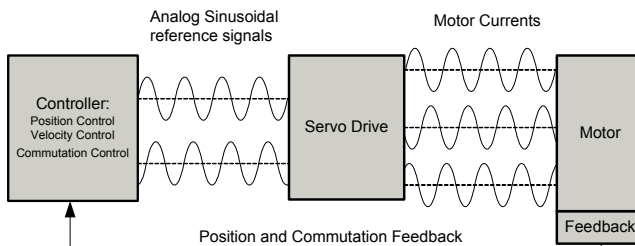

2.3 Power Stage Specifications

The drive datasheet lists the specific values for the following drive power specifications. Note that not all specifications apply to every drive.

TABLE 2.10 Power Stage Specifications

Specification	Units	Description
DC Supply Voltage Range	VDC	Specifies the acceptable DC supply voltage range that the drive will operate within.
DC Bus Over Voltage Limit	VDC	Specifies the maximum DC supply voltage allowable. If the DC bus rises above the over voltage limit, the drive will automatically disable, and will not re-enable until the DC bus voltage falls below the over voltage limit.
AC Supply Voltage Range	VAC	Specifies the acceptable AC supply voltage range that the drive will operate within.
AC Supply Frequency	Hz	Specifies the acceptable frequency of the AC supply line.
Maximum Peak Output Current	A	Pertains to the maximum peak current the drive can output according to hardware limitations. An RMS rating can be obtained by dividing this value by $\sqrt{2}$. With the exception of S-series drives, the maximum peak output duration is inherently limited to occur for no longer than 2 seconds, at which point the current output will foldback over a period of 10 seconds to the continuous current limit in order to protect the motor in stalled condition. Current limiting is implemented in the drive by reducing the output voltage. Most drive models feature peak current limit adjustments. The maximum peak current is needed for fast acceleration and deceleration. Consult the drive datasheet to see which options are available. For more information on the current limit see "Current Limiting Procedure" on page 46 .
Maximum Continuous Output Current	A	Pertains to the maximum continuous current the drive can output according to hardware limitations. An RMS rating can be obtained by dividing this value by $\sqrt{2}$. Most drive models feature continuous current limit adjustments by the use of DIP switches or a potentiometer. Some models also allow an external resistor to be connected between a continuous current limiting pin and signal ground as an additional method of current limiting. Consult the drive datasheet to see which options are available. For more information on setting the current limit see "Current Limiting Procedure" on page 46 .
Maximum Continuous Sine Wave Current	A _{rms}	Pertains to the maximum continuous RMS current that S-series (sinusoidal) drives can output indefinitely. If the continuous RMS current output of the drive exceeds this value, the drive output will be disabled. The drive will re-enable once the RMS current has returned to a level below the maximum continuous sine wave current.
Maximum Power Dissipation at Continuous Current	W	The power dissipation of the drive, assuming approximately 5% power loss to heat dissipation. Calculated by taking 5% of $P=V \cdot I$ at continuous current and peak bus voltage.
Internal Bus Capacitance	μF	The capacitance value between the internal DC bus voltage and power ground.
Internal Shunt Resistance	W	The resistance value of the internal shunt resistor.
Internal Shunt Resistor Power Rating	W	The power rating of the internal shunt resistor.
Internal Shunt Resistor Turn-on Voltage	VDC	The turn-on voltage of the internal shunt resistor.
Minimum Load Inductance	μH	The minimum inductance needed at the output of the drive for proper operation. For a brushless motor, this corresponds to the phase-to-phase inductance. If this minimum inductance is not met, a filter card should be used to add additional inductance. Some motors may operate with slightly less than the required inductance if the bus voltage is low enough. <i>ADVANCED</i> Motion Controls provides various accessories including inductive filter cards for a wide range of drives. See "Inductive Filter Cards" on page 29 for more information.
Shunt Fuse	A	The current rating of the internal shunt resistor fuse.
Bus Fuse	A	The current rating of the input AC line fuses.
Switching Frequency	kHz	The switching frequency of the drive output power stage.

2.4 Command Inputs

The input command source for analog servo drives can be provided by one of the following options. Consult the drive datasheet to see which command source is available for a specific drive.

2.4.1 $\pm 10V$ Analog

A differential or single-ended $\pm 10V$ analog reference signal can be used to command the drive by adjusting the motor current, voltage, or speed, depending on the mode the drive is operating in. For information on the proper wiring of a $\pm 10V$ analog input, see [“Input Reference Wires” on page 36](#).

2.4.2 PWM and Direction

PWM and Direction Input is a specialized type of command that requires a compatible controller. The controller needs two high speed TTL digital outputs to control these drives, one for PWM and the other for Direction. The PWM duty cycle corresponds to the magnitude of the output. Direct control of the PWM switching puts response times in the sub-microsecond range. Since these drives don't take analog inputs for command the need for a D/A converter for drive control is eliminated.

A PWM and Direction drive can be operated in either Direct PWM or Torque Mode PWM.

- In Direct PWM (e.g. "BD" drives) the PWM input directly controls the PWM output, giving direct control of the switching frequency and duty cycle.
- In Torque Mode PWM (e.g. "BDC" drives) the PWM input goes into a PWM-to-Analog converter. The analog signal is then used as a command into the current loop, resulting in a Current Mode drive controlled with PWM and Direction.

2.4.3 Sinusoidal

The "S-Series" of analog servo drives use sinusoidal input signals as the command input. Sinusoidal Input is a specialized type of command that requires a compatible controller with specialized commutation algorithms for proper operation. Two sinusoidal command signals (120 degrees out of phase) from the controller control the commutation and torque of the motor. The controller is effectively closing the current loop by controlling the torque angle (see [Figure 2.6](#)). All feedback goes to the controller, not the drive, including commutation feedback. This allows a wide variety of feedback options, limited only by the compatibility of the controller.

2.5 Feedback Specifications

There are a number of different feedback options available in the family of analog drives. The feedback component can be any device capable of generating a voltage signal proportional to current, velocity, position, or any parameter of interest. Such signals can be provided directly by a potentiometer or indirectly by other feedback devices such as Hall Sensors or Encoders. These latter devices must have their signals converted to a DC voltage, a task performed by the drive circuitry.

Consult a specific drive datasheet to see which feedback devices are available for that drive.

2.5.1 Feedback Polarity

The feedback element must be connected for *negative* feedback. This will cause a difference between the command signal and the feedback signal, called the *error signal*. The drive compares the feedback signal to the command signal to produce the required output to the load by continually reducing the error signal to zero. This becomes important when using an incremental encoder or Hall sensors, as connecting these feedback elements for positive feedback will lead to a motor "run-away" condition. In a case where the feedback lines are connected to the drive with the wrong polarity in either Hall Velocity or Encoder Velocity Mode, the drive will attempt to correct the "error signal" by applying more command to the motor. With the wrong feedback polarity, this will result in a positive feedback run-away condition. To correct this, either change the order that the feedback lines are connected to the drive, or consult the drive datasheet for the appropriate switch on the DIP switch bank that reverses the internal feedback velocity polarity. See the drive datasheet and "[Switch Function Details](#)" on page 44 for more information on DIP switch settings.

2.5.2 Incremental Encoder

Analog servo drives that use encoder feedback utilize two single-ended or differential incremental encoder inputs for velocity control. The encoder provides incremental position feedback that can be extrapolated into very precise velocity information. The encoder signals are read as "pulses" that the drive uses to essentially keep track of the motor's position and direction of rotation. Based on the speed and order in which these pulses are received from the two encoder signals, the drive can interpret the motor velocity.

[Figure 2.7](#) represents differential encoder "pulse" signals, showing how depending on which signal is read first and at what frequency the "pulses" arrive, the speed and direction of the motor shaft can be extrapolated. By keeping track of the number of encoder "pulses" with respect to a known motor "home" position, servo drives are able to ascertain the actual motor location.

FIGURE 2.7 Encoder Feedback Signals

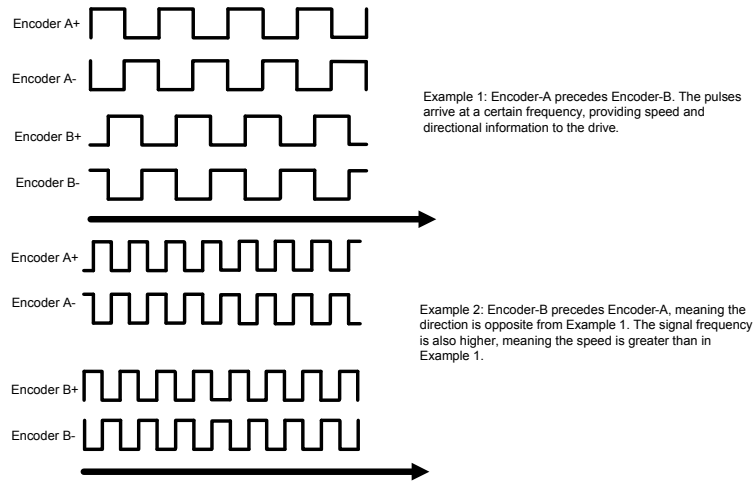

2.5.3 Hall Sensors

Three Phase (Brushless) drives use Hall Sensors for commutation feedback, and in the special case of some drives, for velocity control. The Hall Sensors are built into the motor to detect the position of the rotor magnetic field. These sensors are mounted such that they each generate a square wave with either a 120-degree or 60-degree phase difference over one electrical cycle of the motor.

FIGURE 2.8 Hall Sensor Commutation and Motor Phase Current for 120-Degree Phasing

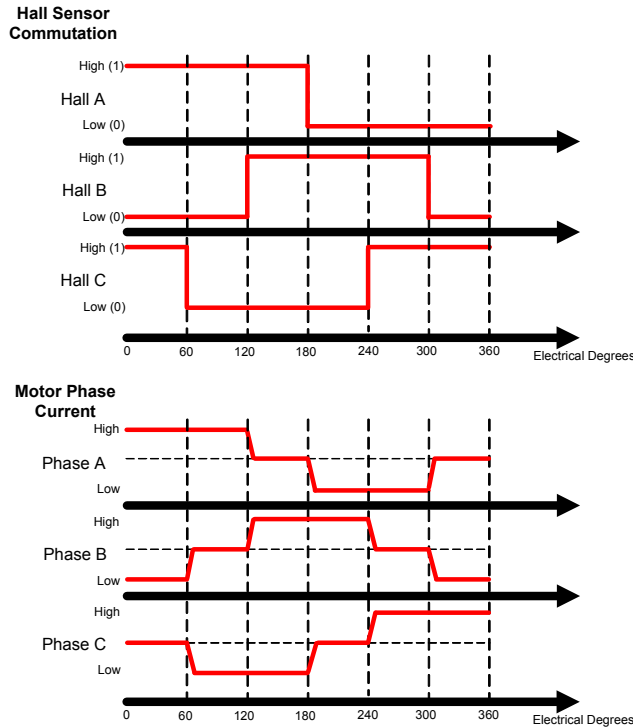

Depending on the motor pole count, there may be more than one electrical cycle for every motor revolution. For every actual mechanical motor revolution, the number of electrical cycles will be the number of motor poles divided by two. For example:

- a 6-pole motor contains 3 electrical cycles per motor revolution
- a 4-pole motor contains 2 electrical cycles per motor revolution
- a 2-pole motor contains 1 electrical cycle per motor revolution

The drive powers two of the three motor phases with DC current during each specific Hall Sensor state:

The table below shows the valid commutation states for both 120-degree and 60-degree phasing.

TABLE 2.11 Commutation Sequence Table

	60 Degree			120 Degree			Motor		
	Hall 1	Hall 2	Hall 3	Hall 1	Hall 2	Hall 3	Phase A	Phase B	Phase C
Valid	1	0	0	1	0	0	HIGH	-	LOW
	1	1	0	1	1	0	-	HIGH	LOW
	1	1	1	0	1	0	LOW	HIGH	-
	0	1	1	0	1	1	LOW	-	HIGH
	0	0	1	0	0	1	-	LOW	HIGH
Invalid	0	0	0	1	0	1	HIGH	LOW	-
	1	0	1	1	1	1	-	-	-
	0	1	0	0	0	0	-	-	-

2.5.4 Tachometer

A DC Tachometer can be used on some drives for velocity control. The tachometer provides an analog DC voltage feedback signal that is related to the actual motor speed and direction. The drive subsequently adjusts the output current based on the error between the tachometer feedback and the input command voltage. The maximum range of the tachometer feedback signal is ±60 VDC.

Some applications may require an increase in the gain of the tachometer input signal. This occurrence will be most common in designs where the tachometer input has a low voltage to RPM scaling ratio. Some drive models offer a through-hole location listed on the specific drive datasheet where a resistor can be added to increase the tachometer gain. Use the drive’s block diagram to determine an appropriate resistor value.

See [“Tachometer Input Gain Scaling” on page 45](#) for more information.

2.6 Modes of Operation

The family of analog drives offers a variety of different control methods. While some drives in the series are designed to operate solely in one mode, on other drives it is possible to select the control method by DIP switch settings (see [“Potentiometer Function Details” on page 43](#) for more information). Consult the datasheet for the drive in use to see which modes are available for use.

The name of the mode refers to which servo loop is being closed in the drive, not the end-result of the application. For instance, a drive operating in Current (Torque) Mode may be used for a positioning application if the external controller is closing the position loop. Oftentimes, mode selection will be dependent on the requirements and capabilities of the controller being used with the drive as well as the end-result application.

2.6.1 Current (Torque) Mode

In Current (Torque) Mode, the input command voltage controls the output current. The drive will adjust the output duty cycle to maintain the commanded output current. This mode is used to control torque for rotary motors (force for linear motors), but the motor speed is not controlled. The output current can be monitored through an analog current monitor output pin. The voltage value read at the [“Current Monitor Output”](#) can be multiplied by a scaling factor found on the drive datasheet to determine the actual output current.



Note

While in Current (Torque) Mode, the drive will maintain a commanded torque output to the motor based on the input reference command. Sudden changes in the motor load may cause the drive to be outputting a high torque command with little load resistance, causing the motor to spin rapidly. Therefore, Current (Torque) Mode is recommended for applications using a digital position controller to maintain system stability.

2.6.2 Duty Cycle (Open Loop) Mode

In Duty Cycle Mode, the input command voltage controls the output PWM duty cycle of the drive, indirectly controlling the output voltage. Note that any fluctuations of the DC supply voltage will affect the voltage output to the motor.



Note

This mode is recommended as a method of controlling the motor velocity when precise velocity control is not critical to the application, and when actual velocity feedback is unavailable.

2.6.3 Hall Velocity Mode

In Hall Velocity Mode, the input command voltage controls the motor velocity, with the Hall Sensor frequency closing the velocity loop. An analog velocity monitor output allows observation of the actual motor speed through a Hz/V scaling factor found on the drive datasheet. The voltage value read at the velocity monitor output can be used to determine the motor RPM through the scaling factor. See [“Velocity Monitor Output” on page 42](#) for the motor RPM equation.



Note

Due to the inherent low resolution of motor mounted Hall Sensors, Hall Velocity Mode is not recommended for low-speed applications below 300 rpm for a 6-pole motor, 600 rpm for a 4-pole motor, or 900 rpm for a 2-pole motor. Hall Velocity Mode is better suited for velocity control applications where the motor will be spinning at higher speeds.

2.6.4 Encoder Velocity Mode

In Encoder Velocity Mode, the input command controls the motor velocity, with the frequency of the encoder pulses closing the velocity loop. An analog velocity monitor output allows observation of the actual motor speed through a kHz/V scaling factor found on the drive datasheet. The voltage value read at the velocity monitor output can be used to determine the motor RPM through the scaling factor. See [“Velocity Monitor Output” on page 42](#) for the motor RPM equation.



Note

The high resolution of motor mounted encoders allows for excellent velocity control and smooth motion at all speeds. Encoder Velocity Mode should be used for applications requiring precise and accurate velocity control, and is especially useful in applications where low-speed smoothness is the objective.

2.6.5 Tachometer Velocity Mode

In Tachometer Velocity Mode, the input command voltage controls the motor velocity. This mode uses an external DC tachometer to close the velocity loop. The drive translates the DC voltage from the tachometer into motor speed and direction information.



Note

DC Tachometers have infinite resolution, allowing for extremely accurate velocity control. However, they also may be susceptible to electrical noise, most notably at low speeds.

2.6.6 Voltage Mode

In Voltage Mode the input reference signal commands a proportional motor voltage regardless of power supply voltage variations. This mode is recommended for velocity control when velocity feedback is unavailable and load variances are small.

2.6.7 IR Compensation Mode

If there is a load torque variation while in Voltage Mode, the motor current will also vary as torque is proportional to motor current. Hence, the motor terminal voltage will be reduced by the voltage drop over the motor winding resistance (IR), resulting in a speed reduction. Thus, motor speed, which is proportional to motor voltage (terminal voltage minus IR drop) varies with the load torque.

In order to compensate for the internal motor voltage drop, a voltage proportional to motor current can be added to the output voltage. An internal resistor adjusts the amount of compensation, and an additional through-hole resistor can be added to the location listed on the drive datasheet. Use caution when adjusting the IR compensation level. If the feedback voltage is high enough to cause a rise in motor voltage with increased motor current, instability occurs. Such a result is due to the fact that increased voltage increases motor speed and thus load current which, in turn, increases motor voltage. If a great deal of motor torque change is anticipated, it may be wise to consider the addition of a speed sensor to the motor (e.g. tachometer, encoder, etc.).

2.6.8 Analog Position Loop Mode

In this mode the feedback device is an analog potentiometer mechanically tied to the positioned object, thus providing position feedback. The wiper of the potentiometer is connected to one of the differential input terminals (-REF). The command is an analog signal, which is connected to the other differential input terminal (+REF).

It is recommended to use a tachometer to close the velocity loop. The input reference gain can be increased in the drive hardware for the Analog Position Loop Mode by ordering the -ANP extension. The following figure is a typical wiring diagram of Analog Position Loop Mode.

FIGURE 2.9 Analog Position Loop Mode Configuration

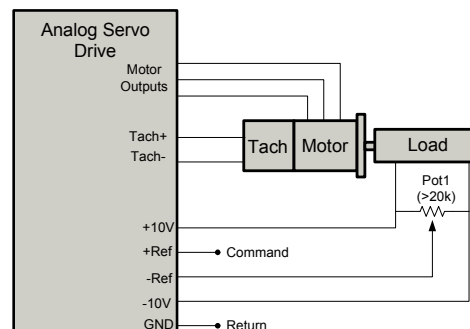

2.7 System Requirements

To successfully incorporate an analog servo drive into your system, you must be sure it will operate properly based on electrical, mechanical, and environmental specifications, follow some simple wiring guidelines, and perhaps make use of some accessories in anticipating impacts on performance. Before selecting an analog servo drive, a user should consider the requirements of their system. This involves calculating the required voltage, current, torque, and power requirements of the system, as well as considering the operating environment and any other equipment the drive will be interfacing with.

2.7.1 Analog Servo Drive Selection and Sizing

Analog servo drives have a given current and voltage rating unique to each drive. Based on the necessary application requirements and the information from the datasheet of the motor being used, a drive may be selected that will best suit the motor capabilities.

A drive should be selected that will meet the peak and continuous current requirements of the application, and operate within the voltage requirements of the system.

Motor Current and Voltage Motor voltage and current requirements are determined based on the maximum required torque and velocity. These requirements can be derived from the application move profiles (Figure 2.10).

FIGURE 2.10 Example Velocity, Torque, and Power Curves

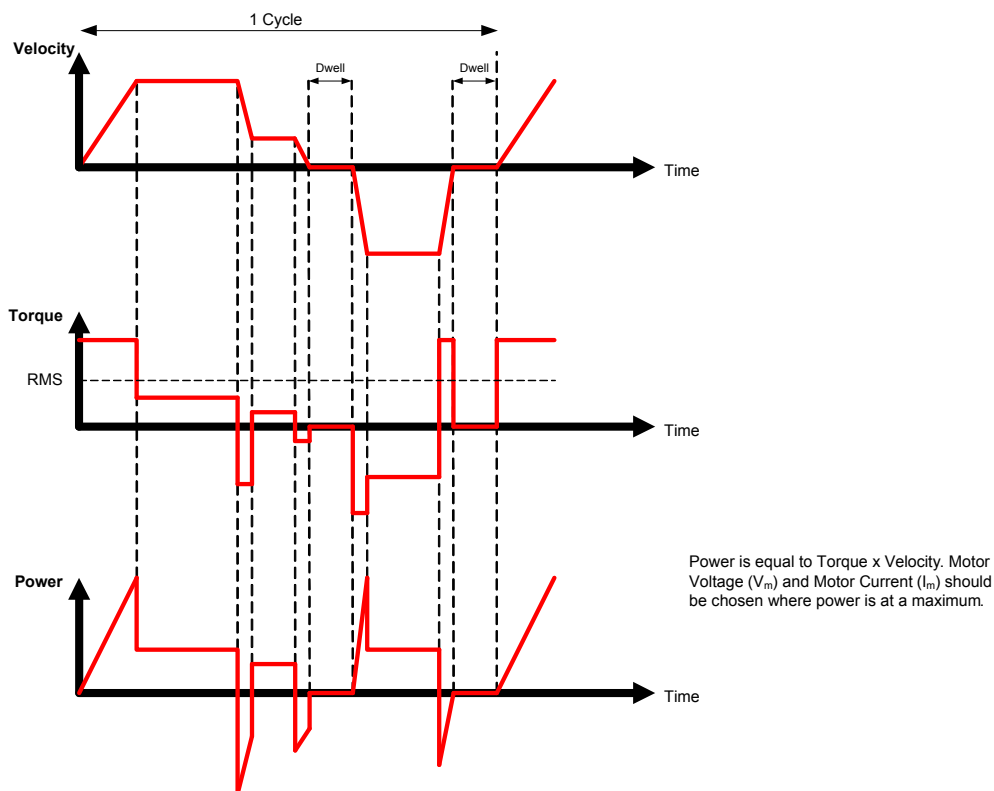

The **motor current** I_M is the required motor current in amps DC, and is related to the torque needed to move the load by the following equation:

$$I_M = \frac{\text{Torque}}{K_T}$$

Where:

K_T -motor torque constant

The motor current will need to be calculated for both continuous and peak operation. The peak torque will be during the acceleration portion of the move profile.

The continuous torque is the average torque required by the system during the move profile, including dwell times. Both peak torque and continuous, or RMS (root mean square) torque need to be calculated. RMS torque can be calculated by plotting torque versus time for one move cycle.

$$T_{RMS} = \sqrt{\frac{\sum_i T_i^2 t_i}{\sum_i t_i}}$$

Here T_i is the torque and t_i is the time during segment i . In the case of a vertical application make sure to include the torque required to overcome gravity.

The system voltage requirement is based on the motor properties and how fast and hard the motor is driven. The system voltage requirement is equal to the **motor voltage**, V_M , required to achieve the move profile. In general, the motor voltage is proportional to the motor speed and the motor current is proportional to the motor shaft torque. Linear motors exhibit the same behavior except that in their case force is proportional to current. These relationships are described by the following equations:

$$V_m = I_m R_m + E$$

$$E = K_e S_m$$

for rotary motors $T = K_t I_m$

for linear motors $F = K_f I_m$

Where:

V_m	-motor voltage
I_m	-motor current (use the maximum current expected for the application)
R_m	-motor line-to-line resistance
E	-motor back-EMF voltage
T	-motor torque
F	-motor force
K_t	-motor torque constant
K_f	-motor force constant
K_e	-voltage constant
S_m	-motor speed (use the maximum speed expected for the application)

The motor manufacturer's data sheet contain K_t (or K_f) and K_e constants. Pay special attention to the units used (metric vs. English) and the amplitude specifications (peak-to-peak vs. RMS, phase-to-phase vs. phase-to-neutral).

The maximum motor terminal voltage and current can be calculated from the above equations. For example, a motor with a $K_e = 10V/Krpm$ and required speed of 3000 RPM would require 30V to operate. In this calculation the IR term (voltage drop across motor winding resistance) is disregarded. Maximum current is maximum torque divided by K_t . For example, a motor with $K_t = 0.5 Nm/A$ and maximum torque of 5 Nm would require 10 amps of current. Continuous current is RMS torque divided by K_t .

Motor Inductance The motor inductance is vital to the operation of analog servo drives, as it ensures that the DC motor current is properly filtered.



Caution

A motor that does not meet the rated minimum inductance value of the drive may damage the drive! If the motor inductance value is less than the minimum required for the selected drive, use of an external filter card is necessary. See "[Inductive Filter Cards](#)" on page 29 for more information.

A minimum motor inductance rating for each specific drive can be found in the datasheet. If the drive is operated below the maximum rated voltage, the minimum load inductance requirement may be reduced.

In the above equations the motor inductance is neglected. In brushless systems the voltage drop caused by the motor inductance can be significant. This is the case in high-speed applications if motors with high inductance and high pole count are used. Please use the following equation to determine motor terminal voltage (must be interpreted as a vector).

$$V_m = (R_m + j\omega L)I_m + E$$

Where:

L	-phase-to-phase motor inductance
ω	-maximum motor current frequency

2.7.2 Power Supply Selection and Sizing

There are several factors to consider when selecting a power supply for an analog servo drive.

- Power Requirements
- Isolation
- Regeneration
- Voltage Ripple

Power Requirements refers to how much voltage and current will be required by the drive in the system. Isolation refers to whether the power supply needs an isolation transformer. Regeneration is the energy the power supply needs to absorb during deceleration. Voltage Ripple is the voltage fluctuation inherent in unregulated supplies.

Power Supply Current and Voltage The power supply current rating is based on the maximum current that will be required by the system. If the power supply powers more than one drive, then the current requirements for each drive should be added together. Due to the nature of servo drives, the current into the drive does not always equal the current out of the drive. However, the power in is equal to the power out. Use the following equation to calculate the power supply output current, I_{PS} , based on the motor voltage and current requirements.

$$I_{PS} = \frac{V_M \cdot I_M}{V_{PS} \cdot (0.98)}$$

Where:

V_{PS}	-nominal power supply voltage
I_M	-motor current
V_M	-motor voltage

Use values of V_m and I_m at the point of maximum power in the move profile, [Figure 2.10](#) (when $V_M I_M = \max$). This will usually be at the end of a hard acceleration when both the torque and speed of the motor is high.

The power supply current is a pulsed DC current ([Figure 2.11](#)): when the MOSFET switch is on, it equals the motor current; when the MOSFET is off it is zero. Therefore, the power supply current is a function of the PWM duty cycle and the motor current (e.g. 30% duty cycle and 12 amps motor current will result in 4 amps power supply current). 30% duty cycle also means that the average motor voltage is 30% of the DC bus voltage. Power supply power is approximately equal to drive output power plus 3 to 5%.



Caution

The only time the power supply current needs to be as high as the drive output current is if the move profile requires maximum current at maximum velocity. In many cases however, maximum current is only required at start up and lower currents are required at higher speeds.

FIGURE 2.11 Unregulated DC Power Supply Current

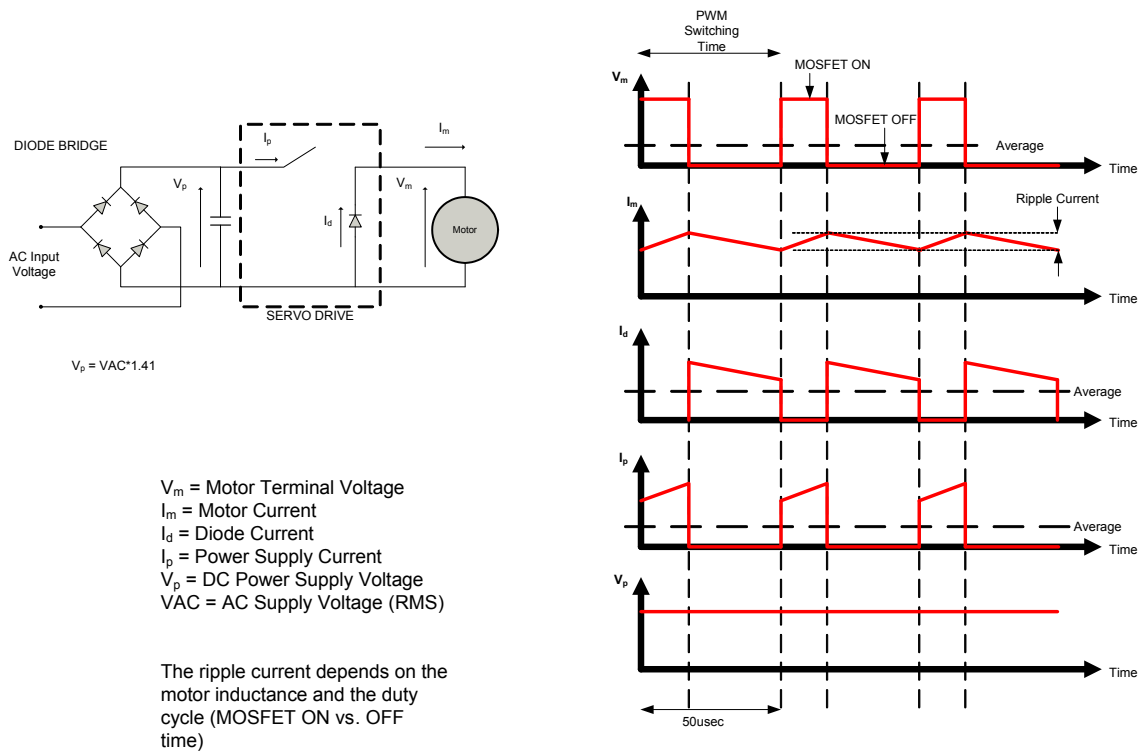

A system will need a certain amount of voltage and current to operate properly. If the power supply has too little voltage/current the system will not perform adequately. If the power supply has too much voltage the drive may shut down due to over voltage, or the drive may be damaged.

To avoid nuisance over- or under-voltage errors caused by fluctuations in the power supply, the ideal system power supply voltage should be at least 10% above the entire system voltage requirement, and at least 10% below the lowest value of the following:

- Drive over voltage
- External shunt regulator turn-on voltage (see [“Regeneration and Shunt Regulators”](#) on page 23)

These percentages also account for the variances in K_t and K_e , and losses in the system external to the drive. The selected margin depends on the system parameter variations.



Caution

Do not select a supply voltage that could cause a mechanical over-speed in the event of a drive malfunction or a runaway condition.

Brushed Motors may have voltage limitations due to the mechanical commutators. Consult the manufacturer's data sheets.

Figure 2.12 provides one possible example of an appropriate system power supply voltage for an analog drive using an external shunt regulator. The over voltage and under voltage shutdown levels on *ADVANCED* Motion Controls drives can be found on the drive datasheet. The shunt regulator turn-on voltage was chosen at an appropriate level to clamp the power supply voltage so it will not exceed the drive over voltage limit during regeneration. The system power supply requirement is based on the motor properties and how much voltage is needed to achieve the application move profile (see “Motor Current and Voltage” on page 17). Keep in mind that the calculated value for V_m is the minimum voltage required to complete moves at the desired speed and torque. There should be at least 10% headroom between the calculated value and the actual power supply voltage to allow for machine changes such as increased friction due to wear, change in load, increased operating speed, etc.

FIGURE 2.12 Power Supply Selection

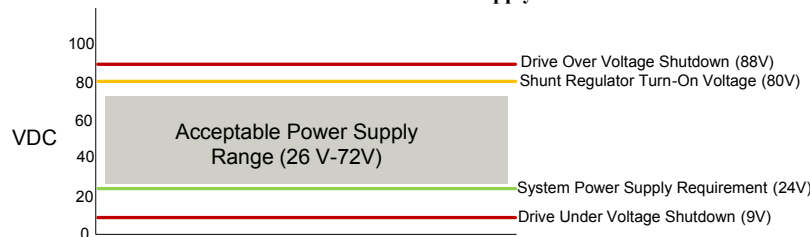

Isolation In systems where an AC line is involved, isolation is required between the AC line and the signal pins on the drive. This applies to all systems except those that use a battery as a power supply. There are two options for isolation:

1. The drive can have built in electrical isolation.
2. The power supply can provide isolation (e.g. a battery or an isolation transformer).

The system must have at least one of these options to operate safely.

Drive with Isolation

Some *ADVANCED* Motion Controls analog drives come with standard electrical isolation, while others can be ordered with isolation as an option (see Figure 2.1, “Analog Product Family Part Numbering Structure,”). To determine if a drive has isolation refer to the functional block diagram on the drive datasheet. The isolation will be indicated by a dashed line through the functional block diagram separating power ground from signal ground.

Drives with an “I” after the current rating in the part number (i.e. 30A8I), drives that are rated to 400 VDC and drives that take AC line voltage for power come standard with isolation. Other drives that do not fall into these categories can be ordered by special request to include isolation.

Power Supply with Isolation

An isolated power supply is either a battery or a power supply that uses an isolation transformer to isolate the AC line voltage from the power supply ground. This allows both the power ground on an isolated power supply and the signal ground on a non-isolated drive to be safely pulled to earth ground. Always use an isolated power supply if there is no isolation in the drive.

Regeneration and Shunt Regulators Use of a shunt regulator is necessary in systems where motor deceleration or a downward motion of the motor load will cause the system's mechanical energy to be regenerated via the drive back onto the power supply.

FIGURE 2.13 Four Quadrant Operation - Regeneration occurs when Torque and Velocity polarity are opposite

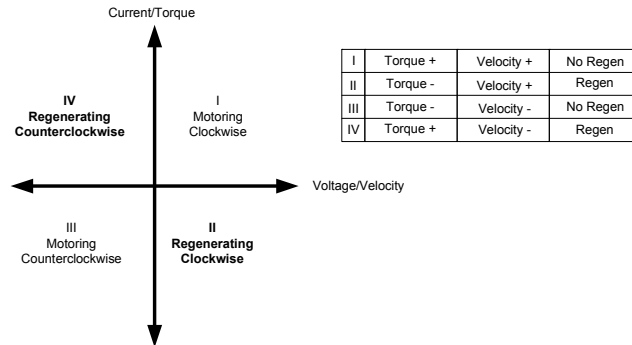

This regenerated energy can charge the power supply capacitors to levels above that of the drive over-voltage shutdown level. If the power supply capacitance is unable to handle this excess energy, or if it is impractical to supply enough capacitance, then an external shunt regulator must be used to dissipate the regenerated energy. Shunt regulators are essentially a resistor placed in parallel with the DC bus. The shunt regulator will "turn-on" at a certain voltage level (set below the drive over-voltage shutdown level) and discharge the regenerated electric energy in the form of heat.

The voltage rise on the power supply capacitors without a shunt regulator, can be calculated according to a simple energy balance equation. The amount of energy transferred to the power supply can be determined through:

$$E_i = E_f$$

Where:

E_i -initial energy
 E_f -final energy

These energy terms can be broken down into the approximate mechanical and electrical terms - capacitive, kinetic, and potential energy. The energy equations for these individual components are as follows:

$$E_c = \frac{1}{2}CV_{nom}^2$$

Where:

E_c -energy stored in a capacitor (joules)
 C -capacitance
 V_{nom} -nominal bus voltage of the system

$$E_r = \frac{1}{2}J\omega^2$$

Where:

E_r	-kinetic (mechanical) energy of the load (joules)
J	-inertia of the load (kg-m ²)
ω	-angular velocity of the load (rads/s)

$$E_p = mgh$$

Where:

E_p	-potential mechanical energy (joules)
m	-mass of the load (kg)
g	-gravitational acceleration (9.81 m/s ²)
h	-vertical height of the load (meters)

During regeneration the kinetic and potential energy will be stored in the power supply's capacitor. To determine the final power supply voltage following a regenerative event, the following equation may be used for most requirements:

$$(E_c \cdot E_r \cdot E_p)_i = (E_c \cdot E_r \cdot E_p)_f$$

$$\frac{1}{2}CV_{nom}^2 + \frac{1}{2}J\omega_i^2 + mgh_i = \frac{1}{2}CV_f^2 + \frac{1}{2}J\omega_f^2 + mgh_f$$

Which simplifies to:

$$V_f = \sqrt{V_{nom}^2 + \frac{J}{C}(\omega_i^2 - \omega_f^2) + \frac{2mg(h_i - h_f)}{C}}$$

The V_f calculated must be below the power supply capacitance voltage rating and the drive over voltage limit. If this is not the case, a shunt regulator is necessary. A shunt regulator is sized in the same way as a motor or drive, i.e. continuous and RMS power dissipation must be determined. The power dissipation requirements can be determined from the application move profile (see [Figure 2.10](#)).

ADVANCED Motion Controls offers a variety of shunt regulators for servo drives. When choosing a shunt regulator, select one with a shunt voltage that is greater than the DC bus voltage of the application but less than the over voltage shutdown of the drive. Verify the need

for a shunt regulator by operating the servo drive under the worst-case braking and deceleration conditions. If the drive shuts off due to over-voltage, a shunt regulator is necessary.

Continuous Regeneration

In the special case where an application requires continuous regeneration (more than a few seconds) then a shunt regulator may not be sufficient to dissipate the regenerative energy. Please contact *ADVANCED* Motion Controls for possible solutions to solve this kind of application. Some examples:

- Web tensioning device
- Electric vehicle rolling down a long hill
- Spinning mass with a very large inertia (grinding wheel, flywheel, centrifuge)
- Heavy lift gantry

Voltage Ripple For the most part, *ADVANCED* Motion Controls analog servo drives are unaffected by voltage ripple from the power supply. The current loop is fast enough to compensate for 60 Hz fluctuations in the bus voltage, and the components in the drive are robust enough to withstand all but the most extreme cases. Peak to peak voltage ripple as high as 25 V is acceptable.

There are some applications where the voltage ripple can cause unacceptable performance. This can become apparent where constant torque or force is critical or when the bus voltage is pulled low during high speed and high current applications. If necessary, the voltage ripple from the power supply can be reduced, either by switching from single phase AC to three phase AC, or by increasing the capacitance of the power supply.

The voltage ripple for a system can be estimated using the equation:

$$V_R = \frac{I_{PS}}{C_{PS}} F_f$$

Where:

V_R	-voltage ripple
C_{PS}	-power supply capacitance
I_{PS}	-power supply output current
F_f	-frequency factor (1/hertz)

The power supply capacitance can be estimated by rearranging the above equation to solve for the capacitance as:

$$C_{PS} = \frac{I_{PS}}{V_R} F_f$$

The frequency factor can be determined from:

$$F_f = \frac{0.42}{f}$$

where f is the AC line frequency in hertz. Note that for half wave rectified power supplies, $f = f/2$.

The power supply output current, if unknown, can be estimated by using information from the output side of the servo drive as given below:

$$I_{PS} = \frac{V_M \cdot I_M}{V_{PS} \cdot (0.98)}$$

Where:

- I_M -current through the motor
- V_{PS} -nominal power supply voltage
- V_M -motor voltage (see [“Motor Current and Voltage” on page 17](#))

2.7.3 Environmental Specifications

To ensure proper operation of an analog servo drive, it is important to evaluate the operating environment prior to installing the drive.

TABLE 2.12 Environmental Specifications

Environmental Specifications	
Parameter	Description
Baseplate Temperature Range	See Drive Datasheet
Humidity	90%, non-condensing
Mechanical Shock	10g, 11ms, Half-sine
Vibration	2 - 2000 Hz @ 2.5g
Altitude	0-3000m

Shock/Vibrations While analog drives are designed to withstand a high degree of mechanical shock and vibration, too much physical abuse can cause erratic behavior, or cause the drive to cease operation entirely. Be sure the drive is securely mounted in the system to reduce the shock and vibration the drive will be exposed to. The best way to secure the drive against mechanical vibration is to use screws to mount the drive against its baseplate. For information on mounting options and procedures, see [“Mounting” on page 39](#) and the dimensional drawings and information on the drive datasheet.



Caution

Care should be taken to ensure the drive is securely mounted in a location where no moving parts will come in contact with the drive.

3

Integration in the Servo System

This chapter will give various details on incorporating an analog servo drive into a system, such as how to properly ground the drive along with the entire system, and how to properly connect motor wires, power supply wires, feedback wires, and inputs into the analog servo drive.

3.1 LVD Requirements

The servo drives covered in the LVD Reference report were investigated as components intended to be installed in complete systems that meet the requirements of the Machinery Directive. In order for these units to be acceptable in the end users' equipment, the following conditions of acceptability must be met.

1. European approved overload and current protection must be provided for the motors as specified in section 7.2 and 7.3 of EN60204.1.
2. A disconnect switch shall be installed in the final system as specified in section 5.3 of EN60204.1.
3. All drives that do not have a grounding terminal must be installed in, and conductively connected to a grounded end use enclosure in order to comply with the accessibility requirements of section 6, and to establish grounding continuity for the system in accordance with section 8 of EN60204.1.
4. A disconnecting device that will prevent the unexpected start-up of a machine shall be provided if the machine could cause injury to persons. This device shall prevent the automatic restarting of the machine after any failure condition shuts the machine down.
5. European approved over current protective devices must be installed in line before the servo drive, these devices shall be installed and rated in accordance with the installation instructions (the installation instructions shall specify an over current rating value as low as possible, but taking into consideration inrush currents, etc.). Servo drives that incorporate their own primary fuses do not need to incorporate over protection in the end users' equipment.

These items should be included in your declaration of incorporation as well as the name and address of your company, description of the equipment, a statement that the servo drives must not be put into service until the machinery into which they are incorporated has been declared in conformity with the provisions of the Machinery Directive, and identification of the person signing.

3.2 CE-EMC Wiring Requirements

The following sections contain installation instructions necessary for meeting EMC requirements.

General

1. Shielded cables must be used for all interconnect cables to the drive and the shield of the cable must be grounded at the closest ground point with the least amount of resistance.
2. The drive's metal enclosure must be grounded to the closest ground point with the least amount of resistance.
3. The drive must be mounted in such a manner that the connectors and exposed printed circuit board are not accessible to be touched by personnel when the product is in operation. If this is unavoidable there must be clear instructions that the drive is not to be touched during operation. This is to avoid possible malfunction due to electrostatic discharge from personnel.

Analog Input Drives

4. A Fair Rite model 0443167251 round suppression core must be fitted to the low level signal interconnect cables to prevent pickup from external RF fields.

PWM Input Drives

5. A Fair Rite model 0443167251 round suppression core must be fitted to the PWM input cable to reduce electromagnetic emissions.

MOSFET Switching Drives

6. A Fair Rite model 0443167251 round suppression core must be fitted at the load cable connector to reduce electromagnetic emissions.
7. An appropriately rated Cosel TAC series AC power filter in combination with a Fair Rite model 5977002701 torroid (placed on the supply end of the filter) must be fitted to the AC supply to any MOSFET drive system in order to reduce conducted emissions fed back into the supply network.

IGBT Switching Drives

8. An appropriately rated Cosel TAC series AC power filter in combination with a Fair Rite model 0443167251 round suppression core (placed on the supply end of the filter) must be fitted to the AC supply to any IGBT drive system in order to reduce conducted emissions fed back into the supply network.
9. A Fair Rite model 0443164151 round suppression core and model 5977003801 torroid must be fitted at the load cable connector to reduce electromagnetic emissions.

Fitting of AC Power Filters

It is possible for noise generated by the machine to "leak" onto the main AC power, and then get distributed to nearby equipment. If this equipment is sensitive, it may be adversely affected by the noise. AC power filters can filter this noise and keep it from getting on the AC power signal. The above mentioned AC power filters should be mounted flat against the

enclosure of the product using the two mounting lugs provided on the filter. Paint should be removed from the enclosure where the filter is fitted to ensure good metal to metal contact. The filter should be mounted as close to the point where the AC power filter enters the enclosure as possible. Also, the AC power cable on the load end of the filter should be routed as far from the AC power cable on the supply end of the filter and all other cables and circuitry to minimize RF coupling.

3.2.1 Ferrite Suppression Core Set-up

If PWM switching noise couples onto the feedback signals or onto the signal ground, then a ferrite suppression core can be used to attenuate the noise. Take the motor leads and wrap them around the suppression core as many times as reasonable possible, usually 2-5 times. Make sure to strip back the cable shield and only wrap the motor wires. There will be two wires for single phased (brushed) motors and 3 wires for three phase (brushless) motors. Wrap the motor wires together as a group around the suppression core and leave the motor case ground wire out of the loop. The suppression core should be located as near to the drive as possible. TDK ZCAT series snap-on filters are recommended for reducing radiated emissions on all I/O cables.

3.2.2 Inductive Filter Cards

Inductive filter cards are added in series with the motor and are used to increase the load inductance in order to meet the minimum load inductance requirement of the drive. They also serve to counteract the effects of line capacitance found in long cable runs and in high voltage systems. These filter cards also have the added benefit of reducing the amount of PWM noise that couples onto the signal lines.

Visit www.a-m-c.com/products/filter_cards.html for information on purchasing *ADVANCED* Motion Controls inductive filter cards.

3.3 Grounding

In most servo systems all the case grounds should be connected to a single Protective Earth (PE) ground point in a "star" configuration. Grounding the case grounds at a central PE ground point reduces the chance for ground loops and helps to minimize high frequency voltage differentials between components. All ground wires must be of a heavy gauge and be as short as possible. The following should be securely grounded at the central PE grounding point:

- Motor chassis
- Controller chassis
- Power supply chassis
- Analog Servo Drive chassis

FIGURE 3.1 System Grounding

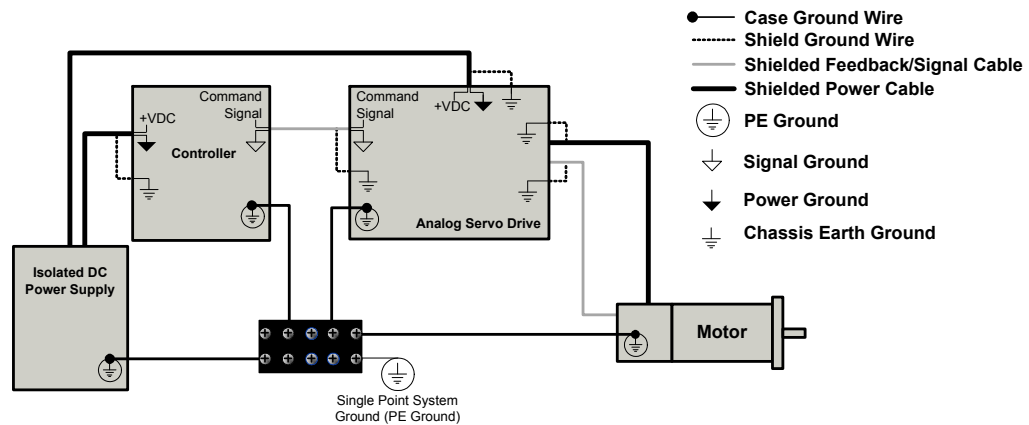

Ground cable shield wires at the drive side to a chassis earth ground point.

The DC power ground and the input reference command signal ground are oftentimes at a different potential than chassis/PE ground. The signal ground of the controller must be connected to the signal ground of the drive to avoid picking up noise due to the "floating" differential servo drive input. In systems using an isolated DC power supply, signal ground and/or power ground can be referenced to chassis ground. First decide if this is both appropriate and safe. If this is the case, they can be grounded at the central grounding point. For systems using AC power referenced to chassis ground, the drive must have internal optical isolation to avoid a short through the the drive's diode bridge.



Grounding is important for safety. The grounding recommendations in this manual may not be appropriate for all applications and system machinery. It is the responsibility of the system designer to follow applicable regulations and guidelines as they apply to the specific servo system.

3.4 Wiring

Servo system wiring typically involves wiring a controller (digital or analog), a servo drive, a power supply, and a motor. Wiring these servo system components is fairly easy when a few simple rules are observed. As with any high efficiency PWM servo drive, the possibility of noise and interference coupling through the cabling and wires can be harmful to overall system performance. Noise in the form of interfering signals can be coupled:

- Capacitively (electrostatic coupling) onto signal wires in the circuit (the effect is more serious for high impedance points).
- Magnetically to closed loops in the signal circuit (independent of impedance levels).
- Electromagnetically to signal wires acting as small antennas for electromagnetic radiation.
- From one part of the circuit to other parts through voltage drops on ground lines.

The main source of noise is the high DV/DT (typically about 1V/nanosecond) of the drive's output power stage. This PWM output can couple back to the signal lines through the output and input wires. The best methods to reduce this effect are to move signal and motor leads apart, use an inductive filter card, add shielding, and use differential inputs at the drive.

Unfortunately, low-frequency magnetic fields are not significantly reduced by metal enclosures. Typical sources are 50 or 60 Hz power transformers and low frequency current changes in the motor leads. Avoid large loop areas in signal, power-supply, and motor wires. Twisted pairs of wires are quite effective in reducing magnetic pick-up because the enclosed area is small, and the signals induced in successive twist cancel.

ADVANCED Motion Controls recommends using the following hand crimp tools for the appropriate I/O and Feedback cable and wire preparation. Consult the drive datasheet to see which connectors are used on a specific drive.

Drive Connector	Hand Crimp Tool Manufacturer and Part Number
16-pin, 2.54 mm spaced friction lock header	Molex: P/N 0638118200
Standard Density D-sub headers	Tyco: P/N 58448-2
High Density D-sub headers	Tyco: P/N 90800-1

3.4.1 Wire Gauge

As the wire diameter decreases, the impedance increases. Higher impedance wire will broadcast more noise than lower impedance wire. Therefore, when selecting the wire gauge for the motor power wires, power supply wires, and ground wires, it is better to err on the side of being too thick rather than too thin. This becomes more critical as the cable length increases. The following table provides recommendations for selecting the appropriate wire size for a specific current. These values should be used as reference only. Consult any applicable national or local electrical codes for specific guidelines.

TABLE 3.1 Current and Wire Gauges

Current (A)	Minimum Wire Size (AWG)	mm ²
10	#20	0.518
15	#18	0.823
20	#16	1.31
35	#14	2.08
45	#12	3.31

Current (A)	Minimum Wire Size (AWG)	mm ²
60	#10	5.26
80	#8	8.37
120	#6	13.3
150	#0	53.5
200	#00	67.4

3.4.2 Motor Wires

The motor power wires supply power from the drive to the motor. Use of a twisted, shielded pair for the motor power cables is recommended to reduce the amount of noise coupling to sensitive components.

- For a brushed motor or voice coil, twist the two motor wires together as a group.
- For a brushless motor, twist all three motor wires together as a group.

Ground the motor power cable shield at one end only to the servo drive chassis ground. The motor power leads should be bundled and shielded in their own cable and kept separate from feedback signal wires.



DO NOT use wire shield to carry motor current or power!

The diagrams below show how an analog servo drive connects to a Brushed (single-phase) and Brushless (three-phase) motor. Notice that the motor wires are shielded, and that the motor housing is grounded to the single point system ground (PE Ground). The cable shield should be grounded at the drive side to chassis ground.

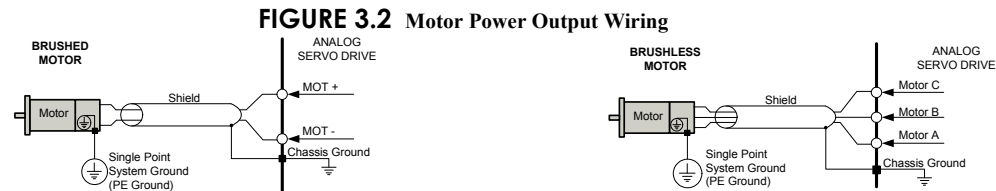

If using relays or other means to disconnect the motor leads, be sure the drive is disabled before reconnecting the motor leads to the drive. Connecting the motor leads to the drive while it is enabled can generate extremely high voltage spikes which will damage the drive.

3.4.3 Power Supply Wires

The PWM current spikes generated by the power output-stage are supplied by the internal power supply capacitors. In order to keep the current ripple on these capacitors to an acceptable level it is necessary to use heavy power supply leads and keep them as short as possible. Reduce the inductance of the power leads by twisting them. Ground the power supply cable shield at one end only to the servo drive chassis ground.

When multiple drives are installed in a single application, precaution regarding ground loops must be taken. Whenever there are two or more possible current paths to a ground connection, damage can occur or noise can be introduced in the system. The following rules apply to all multiple axis installations, regardless of the number of power supplies used (see [Figure 3.3](#)):

1. Run separate power supply leads to each drive directly from the power supply filter capacitor.
2. Never "daisy-chain" any power or DC common connections. Use a "star"-connection instead.

FIGURE 3.3 Multiple Power Supply Wiring

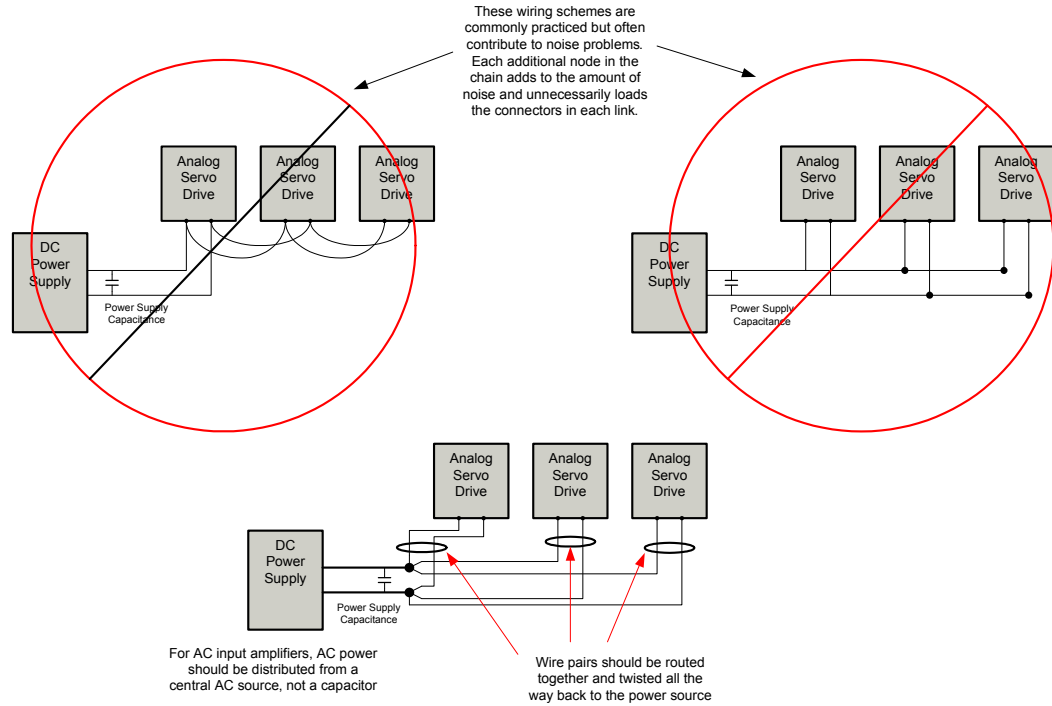

DC Power Supplies For drives using a DC power supply, connect the transformer-isolated DC supply high voltage to the DC Power Input terminal, and the DC supply ground to the power ground terminal.

FIGURE 3.4 DC Power Supply Wiring

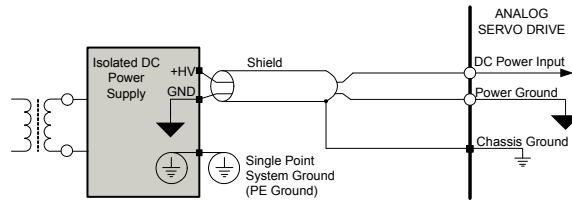

Single Phase AC Power Supplies Drives that accept only single-phase AC line power include a standard 3-prong pluggable AC connector for attachment to an AC supply on the underside of the drive (standard AC models), or on the front face of the drive (FAC models).

FIGURE 3.5 Pluggable AC Line Connectors



Three Phase AC Power Supplies Drives that accept three-phase AC line power have either a 5-contact AC input screw terminal or a 4-port AC input connector. Connect a three phase AC supply to AC1, AC2, and AC3, or L1, L2, and L3, depending on the drive model. On certain models, a single phase AC supply can be connected to any two of the three AC terminals. Consult the drive datasheet to determine if a specific drive model also accepts single phase AC.

FIGURE 3.6 Single or Three Phase AC Line Connections

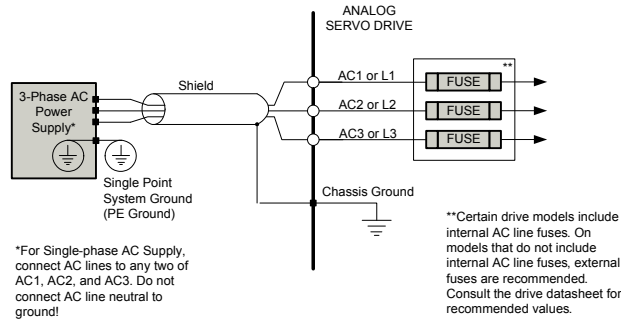

3.4.4 Feedback Wires

Use of a twisted, shielded pair for the feedback wires is recommended. Ground the shield at one end only to the servo drive chassis ground. Route cables and/or wires to minimize their length and exposure to noise sources. The motor power wires are a major source of noise, and the motor feedback wires are susceptible to receiving noise. This is why it is never a good idea to route the motor power wires with the motor feedback wires, even if they are shielded. Although both of these cables originate at the drive and terminate at the motor, try to find separate paths that maintain distance between the two. A rule of thumb for the minimum distance between these wires is 10cm for every 10m of cable length.

FIGURE 3.7 Feedback Wiring

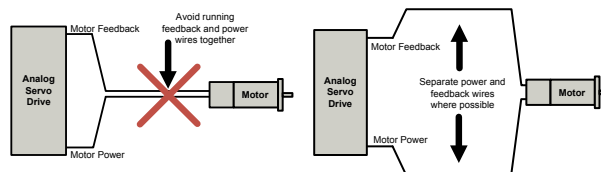

Hall Sensors Brushless drives accept single-ended Hall Sensor feedback for commutation and velocity control. Most drives also include a +6V, 30 mA low voltage supply output that can be used to power the Hall Sensors. Verify on the motor datasheet that the voltage and current rating of the supply output will work with the Hall Sensors before connecting.

FIGURE 3.8 Hall Sensor Input Connections

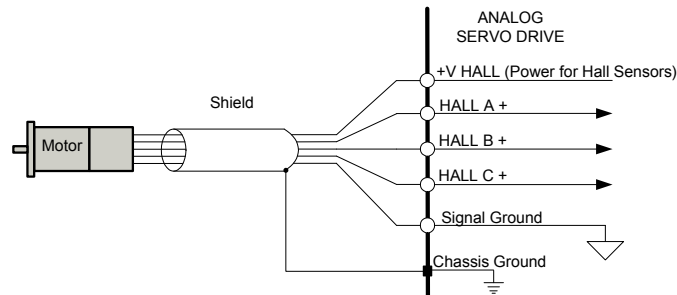

Incremental Encoder Some drive models support either single-ended or differential incremental encoder feedback. If using a single-ended encoder with a drive that accepts differential inputs, leave the negative terminal open. Both the "A" and "B" channels of the encoder are required for operation. Drives that accept differential signals also accept an optional "index" channel that can be used for synchronization and homing. If using the +5V, 150mA (or 250mA) low voltage power supply output from the drive, verify that the supply output voltage and current rating is sufficient for the encoder specifications.

FIGURE 3.9 Incremental Encoder Connections

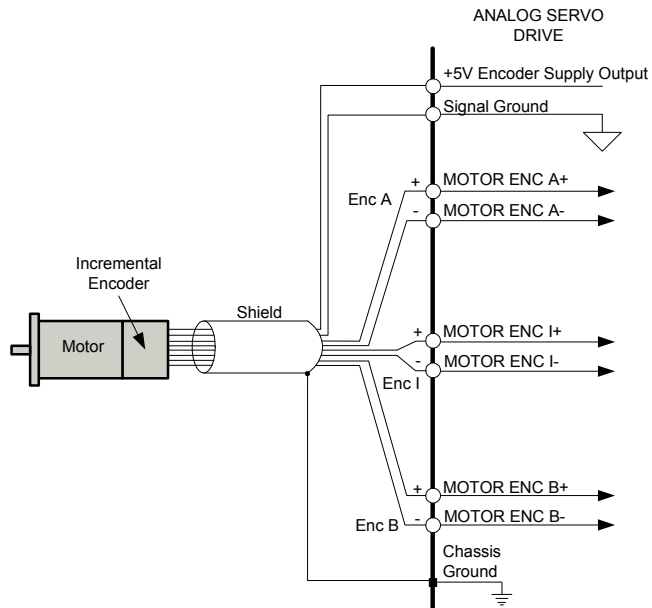

Tachometer For drives that accept a Tachometer for velocity control, connect the negative tachometer input to the tachometer input on the drive, and connect the positive tachometer input to signal ground. The drive must be in Tachometer Velocity mode in order to properly use the tachometer input. See the drive datasheet for specific DIP switch settings. The tachometer has a range of ± 60 VDC. Certain drive models allow scaling of the allowable tachometer voltage range. Consult the drive datasheet for tachometer scaling instructions.

FIGURE 3.10 Tachometer Input Connections

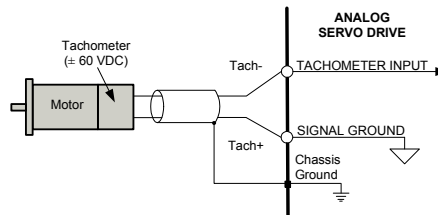

3.4.5 Input Reference Wires

Use of a twisted, shielded pair for the input reference wires is recommended. Connect the reference source "+" to "+REF IN", and the reference source "-" (or common) to "-REF IN". Connect the shield to the servo drive chassis ground. The servo drive's reference input circuit will attenuate the common mode voltage between signal source and drive power grounds.



Notice

In case of a single-ended reference signal, connect the command signal to "+ REF IN" and connect the command return and "- REF IN" to signal ground.

Long signal wires (10-15 feet and up) can also be a source of noise when driven from a typical op-amp output. Due to the inductance and capacitance of the wire the op-amp can oscillate. It is always recommended to set a fixed voltage at the controller and then check the signal at the drive with an oscilloscope to make sure that the signal is noise free.

$\pm 10V$ Analog Input When using a $\pm 10V$ analog signal for an input command, it is important to consider the output impedance of the analog source when interfacing to input circuitry. A poorly designed $\pm 10V$ analog input interface can lead to undesired command signal attenuation. Figure 3.11 shows an external analog source connected to an analog input. The ideal voltage delivered to the input is V_s . However, the voltage drop across R_{source} will reduce the signal being delivered to the drive input. This voltage drop is dependent on the value of R_{source} and the drive's input impedance.

FIGURE 3.11 Analog Source and Drive Input

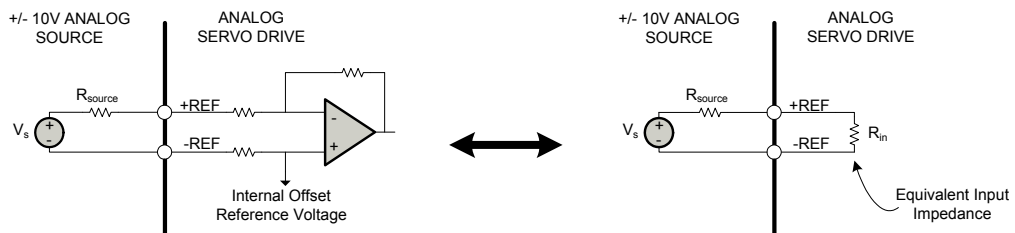

The drive's analog input can be simplified to a single impedance, R_{in} , as shown in Figure 3.11. If the impedance of R_{source} is of the same magnitude or larger than R_{in} , there will be a significant voltage drop across R_{source} . Reduced values of R_{source} cause a lower voltage drop that increases signal integrity. In order to avoid a voltage drop of more than 5% between the source and the drive, it is recommended to use an R_{source} value of less than or equal to 2kohm.

If there is a large output impedance from the analog source, it is recommended to use a buffer circuit between the analog source output and the drive input. A unity gain op-amp circuit as shown in Figure 3.12 will ensure low output impedance with minimal voltage drop.

FIGURE 3.12 Optimized Low Impedance Interface

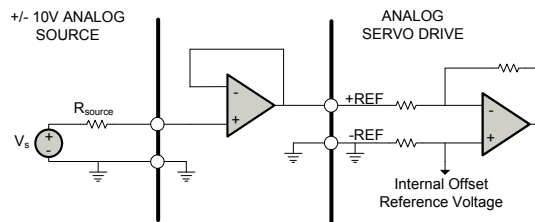

Potentiometer Input Analog servo drives that accept $\pm 10V$ analog input can be commanded with the use of an external potentiometer and a DC supply by varying the DC supply voltage across the potentiometer.

FIGURE 3.13 Potentiometer Input

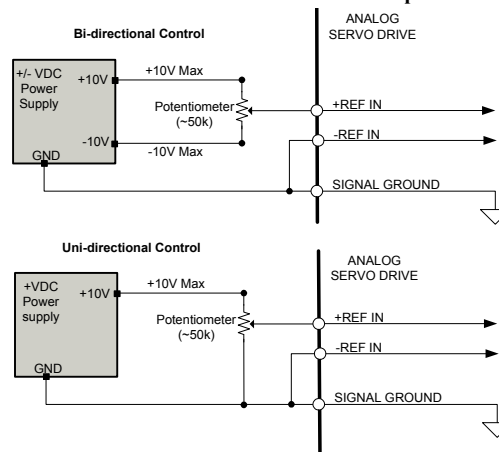

PWM and Direction Inputs On drives that accept a PWM and Direction signal for a command input, the inputs are optically isolated from the power stage of the drive. The PWM and Direction, Inhibit, and Fault I/O will not provide any functionality to the drive unless the optocouplers are activated. Depending on the drive model, there are two methods to activate the optocouplers and thereby activate the drive.

- Some drive models feature a +5V input pin that is used to drive the optocoupler inputs. This +5V supply must be grounded at the negative Inhibit terminal. The positive terminals for the PWM, Direction, and Inhibit inputs are all internally connected to the +5V input. Therefore, the external PWM and Direction input signals should be connected at the negative PWM and Direction terminals. The positive Fault output terminal can also be

connected to the +5V input supply, and when the drive enters a fault stage, the negative Fault output terminal will rise to the +5V supply indicating a fault condition.

FIGURE 3.14 PWM and Direction Optocoupled Inputs, +5V supply input option

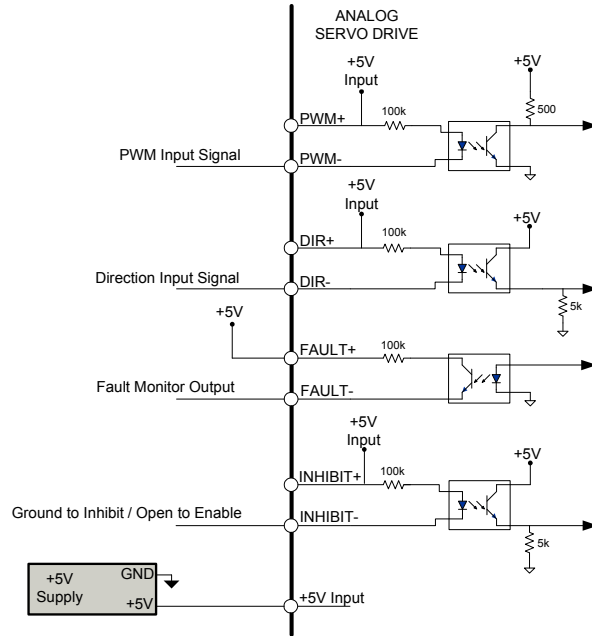

- On drives that do not contain an additional +5V input supply pin, there are two options to activate the optocouplers. The positive terminals of the PWM, Direction, Fault, and Inhibit I/O can be brought to an external +5V supply, or the negative terminals of the PWM, Direction, Fault, and Inhibit I/O can be brought to ground.

FIGURE 3.15 PWM and Direction Optocoupled Inputs

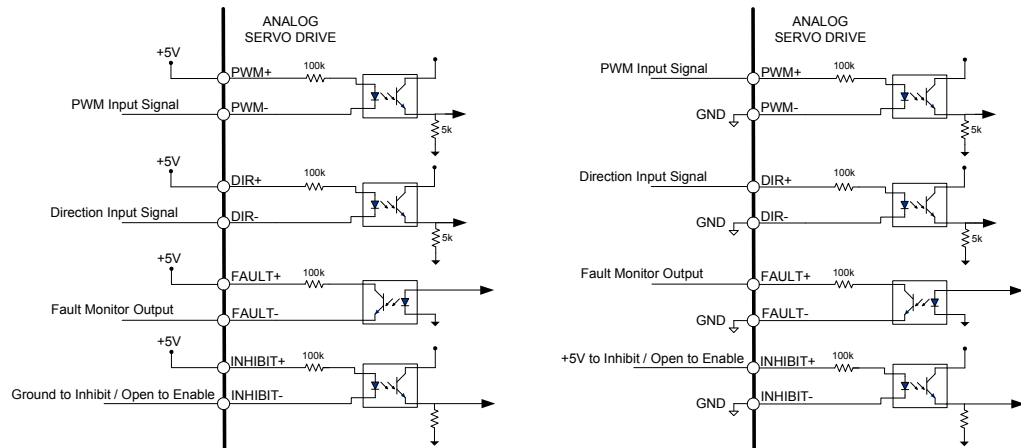

Sinusoidal Input The S-Series of analog servo drives accept two sinusoidal command signals that are 120 degrees out of phase. The sine input signals can be either differential or single-ended. If using a single-ended signal, connect the input to the +REF terminal of the reference input pins, and ground the negative terminal.

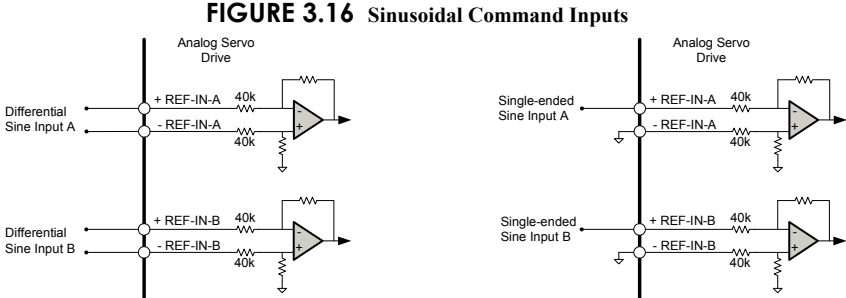

3.5 Mounting

ADVANCED Motion Controls analog servo drives provide mounting hole locations on the baseplate allowing the drive to be mounted either vertically or horizontally. Drives can be mounted to a heatsink or other plane surface, or attached to a lab rail either on a test bench or as part of a larger system. Consult the drive datasheet for specific mounting dimensions and mounting hole locations.



4 Operation

This chapter will describe the operation and setup of an *ADVANCED* Motion Controls analog servo drive.

4.1 Initial Setup and Features

To begin operation with your analog servo drive, be sure to read and understand the previous chapters in this manual as well as the drive datasheet. Be sure that all system specifications and requirements have been met, and become familiar with the capabilities and functions of the drive. Also, be aware of the “[Troubleshooting](#)” section at the end of this manual for solutions to basic operation issues.

Do not install the servo drive into the system without first determining that all chassis power has been removed for at least 10 seconds. Never remove a drive from an installation with power applied. Carefully follow the grounding and wiring instructions in the previous chapters to make sure your system is safely and properly set up.

4.1.1 Pin Function Details

The family of analog drives provide a number of various input and output pins for parameter observation and drive configuration options. Not all drives will have each of the following pin functions. Consult the drive datasheet to see which input/output pin functions are available for each drive.

Current Monitor Output Measured relative to signal ground, power ground, or a separate current monitor ground, depending on the drive model. Consult the drive datasheet to determine the correct ground connection. The current monitor provides an analog voltage output signal that is proportional to the actual drive current output. The scaling factor for each individual drive can be found on the drive datasheet. The drive must be connected to a load in order for the drive to output actual current.

Example Measurement

The current monitor pin on a drive with a current monitor scaling factor of 4 A/V is measured to be 1.3V. This would mean the drive is outputting: $(4 \text{ A/V})(1.3\text{V}) = 5.2\text{A}$.

Current Reference Output Measured relative to signal ground, the current reference provides an analog voltage output signal that is proportional to the command signal to the internal current loop. The drive does not need to be connected to a load to read the current reference output. The internal command current may differ from the actual drive output current due to certain conditions such as a small load, drive faults, undersized power supplies, inhibited drive, etc. The command to the internal current loop can be solved for by the following equation:

$$I_{\text{command}} = V_{\text{current ref}} \cdot \frac{I_{\text{peak}}}{V_{\text{max}}}$$

Where:

I_{command}	-command current to the internal current loop
$V_{\text{current ref}}$	-measured voltage at current reference pin
I_{peak}	-peak current value of the drive
V_{max}	-voltage corresponding to maximum internal current command, value found on drive datasheet; on most drive models $V_{\text{max}} = 7.45\text{V}$

Example Measurement

The current reference pin on a drive with a peak current value of 12A and V_{max} of 7.45V is measured to be 2.63V. Following the above equation to solve for I_{command} the command current to the internal current loop would be **4.24A**.

Inhibit Input This pin provides a +5V TTL input that allows a user to enable/disable the drive by either connecting this pin to ground or by applying a +5VDC voltage level to this pin, referenced to signal ground. By default, the drive will be enabled if this pin is high, and disabled if this pin is low. This logic can be reversed, however, either through DIP switch setting or by removing a SMT jumper from the PCB (consult the drive datasheet to see which option is available; note that removal of the SMT jumper must be done by a person familiar with SMT soldering, and that the drive warranty will be voided if the drive is damaged). This will require all inhibit lines to be brought to ground to enable the drive. Most drives can also be ordered with inverted inhibit logic as well (-INV option). Some drive models allow the drive to be configured so the inhibit input does not trigger a drive fault state. Typically this is achieved by DIP switch setting. Consult the drive datasheet to see if this option is available.

Directional Inhibits

Some drives also include directional inhibit pins that disable motor motion in either the positive or negative direction, typically used for limit switches. These pins do not cause a drive fault condition. They will follow the same logic (either standard or inverted) as the main inhibit/enable input.

Continuous Current Limit Pin The Continuous Current Limit pin can be used to reduce the factory-preset maximum continuous current limit without affecting the peak current limit of the drive by attaching an external resistor between this pin and signal ground. Values for resistors and the corresponding reduction in continuous current are given on the drive datasheet. This continuous current reduction comes secondary to any reductions made by DIP switch settings on the drive and the current limiting potentiometer.

Fault Output This pin provides a +5V TTL output measured relative to signal ground that will indicate when the drive is subject to one of the following fault conditions: inhibit, invalid Hall State, output short circuit, over voltage, over temperature, or power-up reset. On most drive models this pin will read +5V (High) when the drive is in a fault state, but some drives allow the logic to be reversed, so that a 0V (Low) fault output indicates a fault.

Analog drives automatically self-reset once all active fault conditions have been removed. For instance if the DC power supply rises above the over-voltage shutdown level of the drive, the Fault Output will indicate a fault, and the drive will be disabled. Once the DC power supply level is returned to a value below the drive over-voltage shutdown level, the Fault Output will return to the normal state, and the drive will automatically become enabled.

Low Voltage Power Supply Outputs Most drives include low voltage power supply outputs meant for customer use. Consult the drive datasheet to see which low voltage outputs are included on a specific drive.

- **±10V (or ±5V), 3mA Output** - Typically used as an on-board ±10V analog input signal for testing purposes. This output can be used in conjunction with an external potentiometer to vary the input signal between ±10V.
- **+6V, 30mA Output** - Available on three phase (brushless) drive only. This pin provides a +6 VDC output that can be used to power Hall Sensors. Consult the motor datasheet to find out which feedback wire from the motor is the Hall Sensor power supply wire.



Notice

Do not use this +6V supply to power an encoder. An encoder will require a separate power supply. Consult the encoder datasheet or specifications to determine the encoder voltage and current requirements. Typical values are +5VDC at 150mA.

- **+5V, 150 mA (or 250mA) Output** - Can be used as power for an encoder. Consult the motor or encoder datasheet to determine the appropriate encoder voltage and current requirements before connecting this supply.

Velocity Monitor Output This pin provides an analog voltage output that is proportional to the actual motor speed. The scaling factor for each individual drive can be found on the drive datasheet.

- For a drive in Encoder Velocity Mode, substitute the voltage value read at the velocity monitor pin, V_{monitor} into the below equation to determine the motor RPM:

$$\text{Motor Velocity [RPM]} = \frac{V_{\text{monitor}} \cdot \text{Scaling Factor} \cdot 60}{\text{Number of encoder lines}}$$

- For a drive in Hall Velocity Mode, substitute the voltage value read at the velocity monitor pin, V_{monitor} into the below equation to determine the motor RPM:

$$\text{Motor Velocity [RPM]} = \frac{V_{\text{monitor}} \cdot \text{Scaling Factor} \cdot 120}{\text{Number of motor poles}}$$

4.1.2 Potentiometer Function Details

All potentiometers vary in resistance from 0 to 50 kohm, over 12 turns. An additional full turn that does not effect resistance is provided on either end, for a total of 14 turns. When the end of potentiometer travel is reached, it will click once for each additional turn. Consult the drive datasheet to see which potentiometers are included on a specific drive.

TABLE 4.1 Potentiometer Function Details

Potentiometer	Description
Loop Gain Adjustment	This potentiometer must be set completely counter-clockwise in Current Mode. In Velocity, Voltage, or Duty Cycle Mode, this potentiometer adjusts the gain in the velocity forward position of the closed loop. Turning this potentiometer clockwise increases the gain. Start from the full counter-clockwise position, turn the potentiometer clockwise until the motor shaft oscillates, then back off one turn.
Current Limit	<p>This potentiometer adjusts the current limit of the drive. To adjust the current limit, first use any available DIP switches or external current limiting resistors to set the maximum current limits and ratios (consult drive datasheet to see which options are available). If further adjustment is necessary, use the following equation to determine the number of clockwise turns from the full counter-clockwise position necessary to set the desired current limit:</p> $\# \text{ of turns (from full CCW)} = \left(\frac{I_{system}}{I_{max}} \right) 12 + 1$ <p>I_{system} = the desired current limit of the system (typically determined by motor current rating) I_{max} = maximum current capability of the drive; this value is determined after any external current limiting resistors have been used and/or any current scaling or current reduction DIP switches have been set. If no DIP switches or external resistors have been used, then I_{max} is the default maximum continuous current limit set by the drive hardware. See "Current Limiting Procedure" on page 46 for an example of how to use this potentiometer.</p>
Reference Gain	This potentiometer adjusts the ratio between the input signal and the output variable (voltage, current, velocity, or duty cycle). For a specific gain setting, turn this potentiometer fully counter-clockwise, and adjust the command input to 1V. Then turn clockwise while monitoring motor velocity or drive output voltage (depending on mode of operation) until the required output is obtained for the given 1V command. Turning this potentiometer counter-clockwise decreases the reference in gain, while setting this potentiometer in the fully clockwise position makes the whole range of drive output available. This potentiometer may be left in the fully clockwise position if a controller is used to close the velocity or position loops.
Test/Offset	<p>This potentiometer acts as an internal command source for testing when the Test/Offset switch is in the ON position. If the Test/Offset switch is in the OFF position, then this potentiometer can be used to adjust a small amount of command offset in order to compensate for offsets that may be present in the servo system. Turning this potentiometer clockwise adjusts the offset in a negative direction relative to the +Ref input command.</p> <p>Before offset adjustments are made, the reference inputs must be grounded or commanded to 0 volts.</p>
Ramp Time	This potentiometer sets the ramp time for the command input signal. The ramp time can be set for up to 30 seconds in reaching the max command by adjusting the potentiometer fully clockwise. Ramping rates are linear with respect to time and apply to both directions of motion.

Test Points for Potentiometers After the potentiometer adjustments have been completed, the resistance values can be measured for future adjustments or duplication on other servo drives of the same part number. Test points for potentiometer wipers are provided and are located at the foot of all four potentiometers. Resistance measurements are only to be used to duplicate drive settings, since some potentiometers have other resistors in series or parallel. Measure the resistance between the test point and the outer leg of the potentiometer or between the test point and an appropriate ground. See the block diagram on the drive datasheet to determine which ground should be used for each potentiometer.



Notice

Before taking potentiometer resistance measurements, make sure that all potentiometers and DIP switches have been set to the desired settings, and that all I/O and Feedback cables have been removed from the drive, as these can affect resistance measurements.

4.1.3 Switch Function Details

Together with the described functions below certain switches may also be used in selecting the mode of operation, while some may be used strictly for mode selection. Switch implementation and functionality within the drive circuitry is included on the block diagram of the drive datasheet. Consult the drive datasheet to see which switches are included on a specific drive.

TABLE 4.2 Switch Function Details

Switch	Description
Current Scaling	Changes the sensitivity of the current sense, thereby reducing the peak and continuous current limits by a given amount.
Current Loop Proportional Gain Adjustment	Adjusts the proportional gain of the current loop. For drive model S16A8, there are two Current Loop Proportional Gain switches that must be set to the same setting.
Current Limit Ratio	Sets the continuous-to-peak current limit ratio to a given percentage. The default setting for all drives is a continuous-to-peak current limit ratio of 50% (i.e., 12 amp peak limit, 6 amp continuous limit).
Current Loop Integral Gain	Activates or deactivates the current loop integral gain. This switch is OFF by default. For drive model S16A8, there are two Current Loop Integral Gain switches that must be set to the same setting.
RMS Current Limit Setting	Sets the RMS current limit setting on sinusoidal input drives, used to reduce the continuous current limit to a percentage of the maximum continuous limit. Two RMS Current Limit Setting switches are used to set the percentage. See the drive datasheet for specific switch configuration.
Peak Current Limit	Sets the peak current to 50% or 100% of the maximum peak current limit on sinusoidal input drives. Depending on the drive model, there are either two or three Peak Current Limit switches that must all be set to the same setting.
Outer Loop Integration Activation	Activates or deactivates the outer loop integration. For Current Mode, outer loop integration should be deactivated, but should be activated for other modes.
Outer Loop Integral Gain Adjustment	Increases or decreases the integral gain of the outer loop.
Duty Cycle Feedback	Enables/disables the duty cycle feedback. Duty cycle feedback is only enabled when the drive is configured for Duty Cycle Mode.
Hall Sensor Commutation Phasing	Tells the drive the type of Hall sensor phasing the motor has. Switches between 120 and 60 degree phasing.
Test/Offset	Switches the drive between Test mode and Offset mode. In Test mode, the command signal is adjustable via the Test/Offset potentiometer. In Offset mode, the drive will accept commands via the reference inputs, but a small amount of offset can be adjusted in order to compensate for offsets that may be present in the servo system.
PWM and Direction Test Signal	Activates or deactivates the PWM and Direction internal test signal, controlled by the PWM Test Signal Adjustment potentiometer.
Velocity Feedback Polarity	Changes the polarity of the internal feedback signal and the velocity monitor output signal. Inversion of the feedback polarity may be required to prevent a motor run-away condition. See "Motor Problems" on page 61 for more information.
IR Compensation	Activates or deactivates IR feedback. IR feedback should be activated for IR Compensation Mode, and deactivated for other modes.
Inhibit Logic	Sets the logic of the inhibit pins to Active High or Active Low.
Input Range Selection	Sets the voltage range of the sinusoidal command input pins. The input range can be set to $\pm 5V$ or $\pm 10V$. Drives contain two Input Range Selection switches that must set to the same setting.

4.1.4 Adjustable Acceleration and Deceleration Rate

On some drive models, the acceleration and deceleration rates can be set independently using through-hole resistors. The drive datasheet contains specific resistor values and the corresponding ramping time. The rates are based on ± 10 volts to the reference inputs. The "time" listed in the table on the drive datasheet is the time it takes to reach the 10 volt input. The ramping rates are linear with respect to time. For example, if the input were only 5 volts, the time to ramp to this voltage would be half the time to ramp to 10 volts. These locations are silk-screened on the PCB for easy identification. Two SMT jumpers (0 ohm resistors) are required to be set appropriately in order to enable adjustable acceleration/deceleration rate control. The default setting for both jumpers is to disable adjustable rate control. The specific configuration of the jumpers for a drive are given on the drive datasheet.

4.1.5 Tachometer Input Gain Scaling

Standard drive tachometer inputs are typically pre-configured such that the standard 60k input resistance scales the maximum tach input voltage to 60V. The 60k tachometer input resistance is actually populated with a 50k resistor in series with a 10k resistor. Most drives with a tachometer feedback input will also have either a through-hole resistor location in parallel with the 50k resistor or tachometer scaling DIP Switch options.

FIGURE 4.1 Tachometer Input Resistance

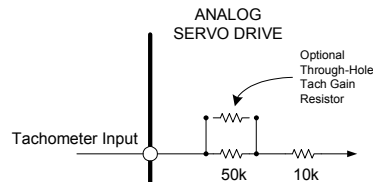

This allows users to reduce the effective input resistance to a value that more closely matches their maximum application feedback voltage in order to increase the tachometer input gain. An appropriate tachometer input resistance value should be at least 1000 times the maximum tachometer voltage feedback value. From zero to infinite resistance (open connection), this through-hole location can scale the tachometer's maximum input voltage range from 10V to 60V.

To determine the maximum feedback voltage for the application:

1. Determine the absolute maximum speed required of the motor for the application (S_m , in kRPM).
2. Look up the tachometer's voltage to speed constant (K_v , in V/kRPM).
3. Calculate for the tachometer's maximum voltage output in the application:

$$V_{max} = K_v \cdot S_m$$

Example

An application's maximum motor speed is 4.7 kRPM, and the tachometer is rated for 7 V/kRPM. Using the above equation, the maximum voltage from the tachometer input, V_{max} , will be 33V. Therefore, the equivalent tachometer input resistance must be at least 33k. Choosing an equivalent resistance value of 35k, solve for the required resistance of the through-hole resistor.

$$\text{Tach Gain Through-Hole Resistor (in kohm)} = \frac{(50 \cdot V_{max}) - 500}{60 - V_{max}} = \frac{(50 \cdot 35) - 500}{60 - 35} = 50k$$

As solved for above, the equivalent 35k resistance can be achieved by adding a 50k through-hole resistor in parallel with the existing 50k resistor on the drive tachometer input.



Notice

Scaling the tachometer input gain is not a required procedure for all applications. Most applications will work well even with low gains. The effect of low gains is only a slower velocity loop response.

4.1.6 Current Limiting Procedure

Before operating a drive, the current output of the drive must be limited based on motor and system current limitations. Depending on the drive model, *ADVANCED* Motion Controls' analog servo drives feature a number of different current limiting methods. However, the procedure for setting the current limit will essentially be the same for each drive. Consult the drive datasheet to see what current limiting options are available on a specific drive.

The current limiting steps should be taken with no power applied to the drive.

1. The following two options may be used separately or in conjunction with each other to reduce the current limits. Keep in mind that any current reductions enacted by the use of an external resistor will come secondary to DIP switch settings.
 - If available, position any current scaling or current limit ratio DIP switches to the desired position (see [“Potentiometer Function Details” on page 43](#)).
 - If available, use an external resistor connected to the Continuous Current Limiting Pin based on the values given on the drive datasheet (see [“Continuous Current Limit Pin” on page 41](#)).
2. If further current limiting is necessary, use the Current Limit potentiometer to "fine tune" the current limit to a final value (see [“Potentiometer Function Details” on page 43](#)).

Example

A 30A8 drive is going to be used with an application having a continuous current requirement of 1.5 amps and a continuous current limit of 2.5 amps, and a peak current requirement of 6 amps, and a peak current limit of 10 amps. The 30A8 has a Current Scaling and Current Limit Ratio switch, a Current Limit potentiometer, and the option of using an external resistor to reduce the continuous current limit. This example will only use the DIP switches and potentiometer.

1. Typically it is recommended to set the current limits of the drive below the continuous and peak current limits of the motor or application, allowing some headroom for safety. In this case, the drive continuous current limit will be chosen at 2 amps, and the peak current limit at 9 amps.
2. Setting the Current Scaling switch to OFF will scale the peak and continuous current limits by half, yielding a peak limit of 15 amps, and a continuous limit of 7.5 amps.
3. Setting the Current Limit Ratio switch to ON will change the continuous-to-peak current ratio to 25%, yielding a peak limit of 15 amps, and a continuous limit of 3.75 amps.
4. To further reduce the current limits to the desired values, the Current Limit potentiometer can be used. Begin with the continuous current requirement, using the equation to determine the number of clockwise turns for the Current Limit potentiometer:

$$\# \text{ of turns} = \frac{2 \text{ amps}}{3.75 \text{ amps}} 12 + 1$$

Solving for the number of turns yields approximately 7.5 turns in the clockwise direction from the fully counter-clockwise position.

5. Since the continuous-to-peak ratio was set at 25% in Step 3, the number of turns calculated above will yield a peak current limit of approximately 8 amps, thereby satisfying both the continuous and peak current requirements of the application.

4.1.7 Drive Set-up Instructions

Single Phase (Brush Type)

1. It is recommended to reduce the drive output current to avoid motor over heating during the setup procedure. Make sure the current has been set appropriately within the system and motor limits based on the procedure outlined in [“Current Limiting Procedure” on page 46](#).
2. Check the power and connect it to the drive. Do not connect the motor lead wires.
3. Make sure the drive is in an enabled state via all inhibit/enable inputs. See drive datasheet for details.
4. Check that the status LED indicates normal operation (GREEN).
5. Set mode according to the drive datasheet for Voltage Mode.
6. Set the Test/Offset switch to Test mode. Measure the voltage across the motor output with a DC voltmeter. Slowly turn the Test/Offset potentiometer; the voltage should vary between \pm bus voltage. Set the output voltage with the Test/Offset potentiometer to a low value.
7. Verify that the load circuit meets the minimum inductance requirements and that the power supply voltage does not exceed the drive rated voltage or 150% of the nominal motor voltage.
8. Turn the power off. Connect the motor. Turn the power back on. Gradually turn the Test/Offset potentiometer to change motor speed in both directions. Set the Test/Offset switch to Offset.
9. Ground both reference inputs and then using the Test/Offset potentiometer, set the motor for zero speed.
10. Set the control mode suitable for the application.

Three Phase (Brushless)

1. It is recommended to reduce the drive output current to avoid motor over heating during the setup procedure. Make sure the current has been set appropriately based on the procedure outlined in [“Current Limiting Procedure” on page 46](#).
2. According to the the mode selection table on the drive datasheet, set the drive for Open Loop Mode, and set the Test/Offset switch to Test.
3. Check the power and connect it to the drive. Do not connect the motor lead wires.
4. Make sure the drive is in an enabled state via all enable inputs. See drive datasheet for details.
5. Set the Hall Sensor Commutation Switch for the appropriate phasing (typically 120 degree). Connect the Hall sensor inputs. The drive status LED should be GREEN. Manually turn the motor shaft one revolution. The LED should remain green. If the LED turns red or changes between green and red:
 - check the Hall Sensor Commutation Switch
 - check power for the Hall Sensors
 - check the voltage level of the Hall inputs (see [Table 4.3](#))
 - for 60 degree phasing interchange Hall 1 and Hall 2
 (for more information see [“Invalid Hall Sensor State \(Brushless Drives only\)” on page 59](#))

TABLE 4.3 Commutation Sequence Table

	60 Degree			120 Degree			Motor		
	Hall 1	Hall 2	Hall 3	Hall 1	Hall 2	Hall 3	Phase A	Phase B	Phase C
Valid	1	0	0	1	0	0	HIGH	-	LOW
	1	1	0	1	1	0	-	HIGH	LOW
	1	1	1	0	1	0	LOW	HIGH	-
	0	1	1	0	1	1	LOW	-	HIGH
	0	0	1	0	0	1	-	LOW	HIGH
	0	0	0	1	0	1	HIGH	LOW	-
Invalid	1	0	1	1	1	1	-	-	-
	0	1	0	0	0	0	-	-	-

6. Remove power. In all, there are six different ways to connect the three motor wires to the Motor A, Motor B, and Motor C pins. All six combinations must be tested to find the proper combination. The correct combination should yield approximately identical motor speed in both directions. If the motor runs slower in one direction, or if the motor shaft has to be moved manually by hand to start the motor, the combination is incorrect. Motor speed can be verified by using the velocity monitor or by measuring the frequency of the Hall Sensors.
7. To begin, connect the three motor wires in any order.
8. Apply power to the drive, and slowly turn the Test/Offset potentiometer in both directions. Observe the motor speed for both directions. Remove power from the drive, and rewire the three motor wires for a different combination. Test all six different combinations before proceeding.
9. Once the proper combination has been found, set the Test/Offset switch to Offset, ground both reference inputs, and then adjust the Test/Offset potentiometer for zero speed.
10. Set the control mode suitable for the application. If necessary, to change the motor direction for a given command input, interchange Hall 1 and Hall 3, then Motor A and Motor B.

Three Phase (Brushless) Drive with Brushed Motor Three Phase (Brushless) drives are also compatible with Single Phase (Brushed) motors. However, because there are no Hall Sensors on a brushed motor, one of the following course of actions must be taken to properly commutate the drive:

- Set the Hall Sensor Commutation Phasing DIP switch for 60-degree phasing. Leave all the Hall Sensor inputs on the drive open. These inputs are internally pulled high to +5V, creating a "1-1-1" commutation state (see Table 4.3 above) which is a valid state in 60-degree phasing. Only use Motor A and Motor B output in this configuration.

or:

- Tie one of the Hall Sensor inputs on the drive to signal ground. Since the Hall Sensor inputs are by default internally brought high to +5V, this will put the drive in a commutation state where two Hall inputs are high, and one is low (as shown in Table 4.3, having all three Hall inputs pulled high is an invalid commutation state in 120-degree phasing). Depending on which Hall Sensor input is tied to ground, consult Table 4.3 to determine which two motor output wires will be conducting current for that specific commutation state.

Sinusoidal Drive (S-Series)

1. Set the current limit to 10% of motor current to avoid high speeds. See the drive datasheet for current limiting options.
2. Check the power and connect it to the drive. Do not connect the motor lead wires.
3. Make sure the drive is in an enabled state via all enable inputs. See drive datasheet for details.
4. Since the feedback and commutation on S-Series analog servo drives is fed back to the external motion controller, the setup procedure will be dependent on the type of controller in use. Consult the instructions for the external motion controller to determine the proper setup method.

4.1.8 Tuning Procedure

The standard tuning values used in *ADVANCED* Motion Controls analog servo drives are conservative and work well in over 90% of applications. However some applications and some motors require more complete current loop tuning to achieve the desired performance. The following are indications that additional current loop tuning is necessary:

- Motor rapidly overheats even at low current
- Drive rapidly overheats even at low current
- Vibration sound comes from the drive or motor
- The motor has a high inductance (+10mH)
- The motor has a low inductance (near minimum rating of the drive)
- Slow system response times
- Excessive torque ripple
- Difficulty tuning position or velocity loops
- Electrical noise problems
- High power supply voltage (power supply is significantly higher than the motor voltage rating or near the drive's upper voltage limit)
- Low power supply voltage (power supply voltage is near the drive's lower voltage limit)

The above indicators are subjective and suggest that the current loop may need to be tuned. These can also be signs of other problems not related to current loop tuning.

The resistors and capacitors shown under the current control block on the datasheet block diagram determine the frequency response of the current loop. It is important to tune the current loop appropriately for the motor inductance and resistance, as well as the bus voltage to obtain optimum performance. Brush type and Brushless drives have a single current loop, while Sinusoidal (S-Series) drives have three current loops. All three loops must be tuned the same or the drive will not operate properly. The loop gain and integrator capacitance of the current loop must both be adjusted for the tuning to be complete.



Caution

Improper current loop tuning may result in permanent drive and/or motor damage regardless of drive current limits.

Since most *ADVANCED* Motion Controls servo drives close the current loop internally, poor current loop tuning cannot be corrected with tuning from an external controller. Only after the current loop tuning is complete can optimal performance be achieved with the velocity and position loops.

The general current loop tuning procedure follows these steps:

1. Determine if additional current loop tuning is necessary.
2. If available, tune the drive using the current loop DIP switches.
3. If the current loop cannot be satisfactorily tuned with the DIP switches, then the current loop components must be changed.
 - Tune the current loop proportional gain.
 - Tune the current loop integral gain.
4. Once the current loop is tuned, then the velocity and/or position loops may be tuned as well if necessary.

Current Loop Proportional Gain Adjustment The Current Loop Gain should be adjusted with the motor uncoupled from the load, and the motor secured as sudden motor shaft movement may occur. The following points should be kept in mind before beginning the tuning procedure:

- Brushless drives should be configured for 60 degree phasing in order to get output current. The current can be measured through either motor phase A or B.
 - For Sinusoidal (S-Series) drives, connect the function generator to +REF-IN-A and signal ground, and measure the current through motor phase A.
1. Use the DIP switches and Current Limit Potentiometer to select Current Mode, the input range (if applicable) and to set the appropriate current limit for the motor (note that S-Series drives are automatically in Current Mode).
 2. Connect only the motor power leads to the drive. No other connections should be made at this point.
 3. Using a function generator, apply a ± 0.5 V, 50-100 Hz square wave reference signal to the input reference pins.
 4. Short out the current loop integrator capacitor(s) using the appropriate DIP switches or jumpers (see the specific drive datasheet and block diagram for details).
 5. Apply power to the drive. Use a bus voltage that is approximate to the desired application voltage or the current loop compensation will not be correct.
 6. The drive should be enabled (GREEN LED). Observe the motor current using a current probe or resistor in series with the motor (<10% of motor resistance). This observation should be done for both the high and low current loop gain (see drive datasheet for available current loop gain DIP switch settings). Different drives need to be set up differently to view the current loop response properly, as shown in the following figures.

FIGURE 4.2 Brushed Drives

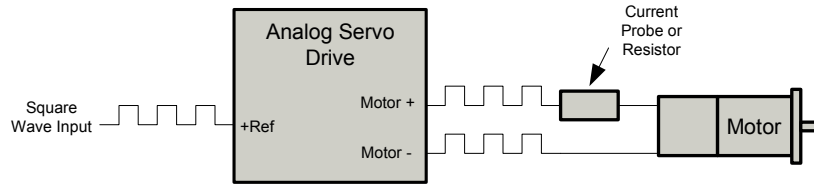

Since the two motor wires are in series, the current through the wires is the same. The current probe can be attached to either wire with the same results. To keep the motor from turning during the tuning process the motor shaft must be locked.

FIGURE 4.3 Brushless Drives

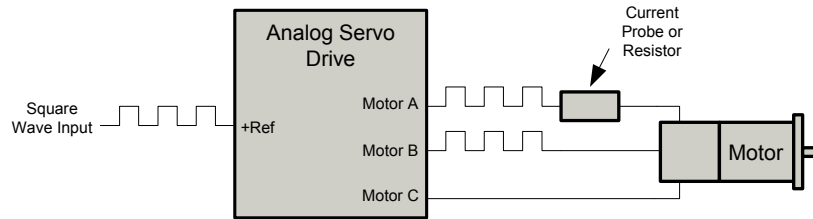

The current out of the drive can be forced to go through Motor A and Motor B by:
 1) Disconnecting the Hall sensors from the drive
 2) Setting the 60/120 degree phasing switch to 60 degrees

The motor shaft does not need to be locked since the drive will not commutate without the Hall Sensors.

FIGURE 4.4 S-Series Drives

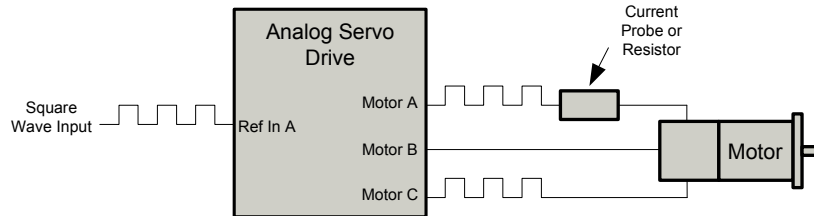

The current out of the drive can be forced to go through Motor A and Motor C by applying the square wave command signal to Ref In A only. Attach the current probe to either Motor A or Motor C.

The motor shaft does not need to be locked since the drive is not commutating.

- The drive output should follow the input command. The best response will be a critically damped output waveform, similar to what is shown in [Figure 4.5](#).

FIGURE 4.5 Current Loop Response

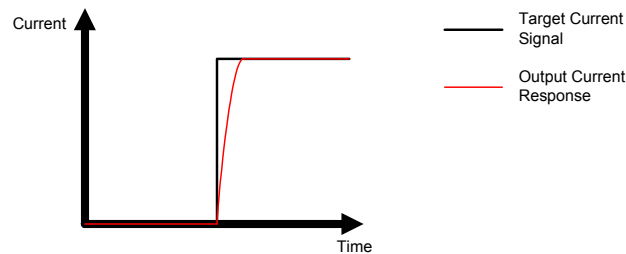

8. If neither current loop gain DIP switch position gives a proper square wave response, then the current loop gain resistors may need to be changed to optimize the response. See [“Through-hole Component Tuning” on page 54](#) for more information.
9. When the proper response has been achieved, remove the input signal from the drive, and disconnect power.

Current Loop Integrator Adjustment

1. Enable the Current Loop Integrator through DIP switch or jumper settings (see the drive datasheet for available options).
2. Using a function generator, apply a $\pm 0.5V$, 50-100 Hz square wave reference signal.
3. Apply power to the drive. Use a bus voltage that is approximate to the desired application voltage or the current loop compensation will not be correct.
4. The drive should be enabled (GREEN LED). Observe the motor current using a current probe or resistor in series with the motor (<10% of motor resistance). If available, use any DIP switches to adjust the current loop integral gain capacitance. The output should settle to a flat top with minimal current following error (difference between commanded current and actual current). There can be some overshoot, but it should be less than 10%.



Notice

Because the oscilloscope measurements are voltage representations of current, the commanded and actual currents will most likely have different current to voltage scalings and tolerances. Therefore, even with perfect current loop tuning, the two amplitudes (scope traces) may not line up as shown in [Figure 4.5](#).

5. If the square wave output overshoots too much or is over-damped (sluggish), the current loop integrator capacitor will need to be changed to optimize the response. See [“Through-hole Component Tuning” on page 54](#) for more information.

Voltage or Velocity Loop Tuning

These adjustments should initially be performed with the motor uncoupled from the mechanical load.

Configure the drive for the desired operation mode using the DIP switch settings (see the block diagram on the specific drive datasheet).

- **Voltage Loop or Duty Cycle Loop**- Compensating the voltage loop requires the least amount of effort. Turn the Loop Gain potentiometer clockwise until oscillation occurs, then back off one turn.
- **IR Feedback Loop** - Start with a very high (or open) IR feedback resistor with an unloaded motor shaft. Command a low motor speed (about 20-200 RPM). Without the IR feedback the motor shaft can be stalled easily. Decreasing the IR feedback resistor will make the motor shaft more difficult to stop. Too much IR feedback, i.e. too low a resistor value, will cause motor run-away when torque is applied to the motor shaft.
- **Velocity Loop (Encoder, Halls, or Tachometer)** - The velocity loop response is determined by the Loop Gain potentiometer. A larger resistance value (clockwise) results in a faster response. The velocity integrator capacitor can be used to compensate for a large load inertia. A large load inertia will require a larger capacitor value. Either using the DIP switches to add in an extra capacitor or installing a through-hole capacitor may accomplish this (see [“Through-hole Component Tuning” on page 54](#) for more information). The need for an extra capacitor can be verified by shorting out the velocity integrator capacitor by DIP switch setting. If the velocity loop is stable with the capacitor

shorted out, and unstable with the capacitor in the circuit, then a larger capacitor value is needed.

Analog Position Loop Use of an encoder or tachometer is recommended to obtain a responsive position loop, since the position loop is closed around the velocity loop. First the velocity loop must be stabilized (or voltage loop for undemanding applications). The position loop gain is determined by the fixed gain of the input differential amplifier of the drive. For best results the servo drive can be ordered with a higher differential gain.



Through-hole Component Tuning

In general, *ADVANCED* Motion Controls analog servo drives will not need to be further tuned with through-hole components. However, for applications requiring more precise tuning than what is offered by the DIP switches and potentiometers, the drive can be manually modified with through-hole resistors and capacitors as denoted in [Table A.1](#) below. On most analog drives, the through-hole locations are not populated when the drive is shipped. S-Series drives however are shipped with through-hole components in pin receptacles for easy removal.

It is recommended to contact *ADVANCED* Motion Controls to discuss application requirements and proper drive tuning prior to making any adjustments.



Notice

Any damage done to the drive while performing these modifications will void the product warranty.

Before attempting to add through-hole components to the board, see [“Tuning Procedure” on page 49](#). Some general rules to follow when adding through-hole components are:

- A larger resistor value will increase the proportional gain, and therefore create a faster response time.
- Use non-polarized capacitors.
- A larger capacitor value will increase the integration time, and therefore create a slower response time.

A.1 Through-Hole Tuning

Proper tuning using through-hole components will require careful observation of the loop response on a digital oscilloscope to find the optimal through-hole component values for the specific application.

The following are some helpful hints to make the loop tuning process easier:

- **Use pin receptacles to reduce the need for soldering** - Some drives have pin receptacles that make it easy to change the tuning resistors and capacitors without the need for soldering. Other drives do not have these receptacles, so soldering is required. To avoid the need to solder every time a tuning value needs to be changed a pin receptacle can be soldered into the the through hole location of the tuning component.

- **Use a potentiometer to find the correct current loop gain value** - A potentiometer can be used to continuously adjust the gain resistance value during the tuning process. Install a potentiometer in place of the gain resistor. Adjust the potentiometer while viewing the current loop response on an oscilloscope. When the optimal response is achieved turn off the drive, remove the potentiometer, and measure the potentiometer resistance. Use the closest resistor value available. (Note: This method will not work if the optimal tuning value is beyond the range of the potentiometer. This method also does not work for sine drives since it is difficult to keep the tuning values in the three current loops the same).
- **Progressively double the resistance value when tuning the current loop gain for faster results** - If the gain resistor needs to be increased during the tuning process the fastest results are achieved by doubling the resistance from the last value tried. Use this method until overshoot is observed and then fine tune from there.
- **Be aware of any components that are in parallel with the values you are trying to tune** - On some drives, there may be one or more gain resistors in parallel with the through-hole resistor location. The equivalent resistance value of the SMT resistors on the board and the additional through-hole resistor will be limited by the smallest resistance value of the group of resistors in parallel. Consult the block diagram on the drive datasheet to determine the specific resistor values. The same situation can occur when trying to decrease the integrator capacitor value, since capacitors in parallel will be added together.
- **Safety**



Always remove power when changing components on the drive.



Float the oscilloscope and function generator grounds to avoid large ground currents.



Decouple the motor from the load to avoid being injured by sudden motor movements.

Table A.1 lists the different through-hole components that can be used for loop tuning. Some models require more than one component that must have identical values. Consult the drive datasheet to see which options are available for a specific drive. Please contact *ADVANCED* Motion Controls Applications Engineering for assistance in determining the PCB location of the through-hole component options for the drive model in use.

TABLE A.1 Through-Hole Tuning Component

Component	Description
Current Loop Proportional Gain Resistor	Through-hole resistor that can be added for more precise current loop tuning.
Current Loop Integrator Capacitor	Through-hole capacitor that can be added for more precise current loop tuning.
Velocity Loop Integrator Capacitor	Through-hole capacitor that can be added for more precise velocity loop tuning.

A.1.1 Procedure

Before changing any components on the PCB, follow the steps in “[Tuning Procedure](#)” on [page 49](#) to determine if any additional tuning is necessary. Observe the drive output current response on an oscilloscope for all the different DIP switch gain settings (if available on the drive in use). If further tuning is necessary or desired, please contact *ADVANCED* Motion Controls before proceeding through the through following steps.



Remember that for Sinusoidal Input (S-Series) drives, all three current loops must have identical through-hole component values (i.e. the through-hole resistor value for phase A must match the through-hole resistor values for phases B and C, and the through-hole capacitor value for phase A must match the through-hole capacitor values for phases B and C).

Tune the Current Loop Proportional Gain

1. Follow the steps outlined in “[Current Loop Proportional Gain Adjustment](#)” on [page 50](#) up through Step 8.
2. Observe the drive current response on an oscilloscope. Small step tuning is different than large step tuning, so adjust the function generator square wave amplitude so the drive outputs a current step similar to what will be expected in typical operation.
 - If the current response does not rise quickly enough to the step input command, or if it never reaches the input command, the equivalent resistance of the current loop proportional gain resistor will need to be increased. This will increase the current loop proportional gain, and achieve a faster, more aggressive response.
 - If the current response overshoots the step input command, the equivalent resistance of the current loop proportional gain resistor will need to be decreased. This will decrease the current loop proportional gain, and provide a slower, more stable response.
3. Finding an acceptable equivalent resistance may take a few iterations. As outlined in the previous section, using pin receptacles or an external potentiometer will make the process easier. Remember to remove power from the drive prior to removing or adding any components to the PCB. Also remember that it is not just the through-hole resistor value that is important, but the equivalent resistance of the through-hole resistor and any SMT resistors that may be in parallel with the through-hole location. Use the block diagram on the drive datasheet to assist in determining the equivalent gain resistance.
4. Use an equivalent resistance value that brings the current response right to the point of overshoot. If there is a large amount of overshoot, or if there are oscillations, decrease the equivalent resistance value until there is little or no overshoot. Depending on the application requirements, a little overshoot is acceptable, but should never exceed 10%.
5. When an acceptable resistance value has been found, remove power from the drive.

Tune the Current Loop Integral Gain

1. After the proportional gain resistance has been adjusted to an acceptable value, re-enable the current loop integrator capacitor (either through DIP switch or jumper settings, depending on the drive model).

2. Using the same function generator input command as in the previous section, apply power to the drive and observe the current loop response on an oscilloscope.
3. Depending on the drive model, the current loop integrator capacitor can be changed or shorted out of the circuit by DIP switch setting. Test both settings while observing the current loop response.
 - If the current response square wave oscillates or overshoots, a larger equivalent capacitance value is necessary.
 - If the current response square wave corners are too rounded, a smaller equivalent capacitance value is necessary to sharpen the corners.
4. As in the previous section, using pin receptacles at the through-hole locations will greatly assist in finding an acceptable capacitance value. Also keep in mind that the through-hole capacitor location may be in parallel with SMT capacitors on the PCB. Use the block diagram on the drive datasheet to determine the equivalent integrator capacitance value (capacitors in parallel add together).
5. Although the ideal current loop response after integral gain tuning will be a critically damped square wave, the application requirements will determine what the desired response will be (i.e. how much overshoot, steady-state error, oscillation, is acceptable).

Velocity Loop Integral Gain Tuning The velocity loop proportional gain is adjusted by the on-board Loop Gain potentiometer. The velocity loop integral gain can be adjusted by DIP switch settings similar to the current loop integral gain (capacitance value can be changed, capacitor can be shorted out, extra capacitor can be added in parallel). However, some drive models also include additional through-hole locations where through-hole capacitors can be added to further adjust the velocity loop integral gain. As in tuning the current loop integral gain, use larger value equivalent capacitors to correct for overshoot or oscillation, and smaller value equivalent capacitors for a quicker response time.

This section discusses how to ensure optimum performance and, if necessary, get assistance from the factory.

B.1 Fault Conditions and Symptoms

An inoperative drive can indicate any of the following fault conditions:

- over-temperature
- over-voltage
- under-voltage
- short-circuits
- invalid commutation
- inhibit input
- power-on reset

All of the above fault conditions are self-reset by the drive. Once the fault condition is removed the drive will become operative again without cycling power. To determine whether the drive is in a fault state, measure the “Fault Output” pin with a digital multimeter or voltmeter. A high at this pin (or a low, depending on the drive model and configuration - see drive datasheet) will indicate that the drive is subject to one of the above fault conditions, and the drive will be disabled until the drive is no longer in a fault state. To remove the fault condition, follow the instructions in the sections below describing each possible fault state.

Over-Temperature Verify that the baseplate temperature is less than the maximum allowable baseplate temperature as denoted on the drive datasheet, typically 65°C (149°F) or 75°C (167°F). The drive remains disabled until the temperature at the drive baseplate falls below this threshold.

Over-Voltage Shutdown

1. Check the DC power supply voltage for a value above the drive over-voltage shutdown limit. If the DC bus voltage is above this limit, check the AC power line connected to the DC power supply for proper value.
2. Check the regenerative energy absorbed during deceleration. This is done by monitoring the DC bus voltage with a voltmeter or oscilloscope. If the DC bus voltage increases above the drive over-voltage shutdown limit during deceleration or regeneration, a shunt

regulator may be necessary. See [“Regeneration and Shunt Regulators” on page 23](#) for more information.

Under-Voltage Shutdown Verify power supply voltages for minimum conditions per specifications. Also note that the drive will pull the power supply voltage down if the power supply cannot provide the required current for the drive. This could occur when high current is demanded and the power supply is pulled below the minimum operating voltage required by the drive.

Short Circuit Fault

1. Check each motor lead for shorts with respect to motor housing and power ground. If the motor is shorted it will not rotate freely when no power is applied while it is uncoupled from the load.
2. Disconnect the motor leads to see if the drive will enable without the motor connected. If the drive enables with the motor disconnected, there is a possible short circuit in the motor wiring.
3. Measure motor armature resistance between motor leads with the drive disconnected. Verify these measurements against the motor datasheet to determine if there is a short or open circuit in the motor windings.

Invalid Hall Sensor State (Brushless Drives only) See the “Commutation Sequence” table in [“Hall Sensors” on page 12](#) for valid commutation states. If the drive is disabled check the following:

1. Make sure that the Hall Sensor Commutation Phasing switch is in the correct setting per motor data sheets. When driving a single phase (brushed type) motor with a three phase (brushless) drive use the 60-degree phase setting (see [“Three Phase \(Brushless\) Drive with Brushed Motor” on page 48](#) for more information on this particular configuration).
2. Check the voltage levels for all the Hall Sensor inputs. Turn the motor by hand while measuring the Hall Sensor inputs to verify that all three Hall Sensors are changing. The voltage should read approximately +5V for a "high (1)" Hall state, and approximately 0V for a "low (0)" Hall state.
3. Make sure all Hall Sensor lines are connected properly.

Inhibit Input Check inhibit input for correct polarity (that is, pull-to-ground to inhibit or pull-to-ground to enable). Inhibit configuration depends either on the DIP switch settings or a 0 ohm SMT resistor marked on the board. Also, keep in mind that noise on the inhibit line could be a cause for a false inhibit signal being given to the drive.

Power-On Reset All drives have a power-on reset function to ensure that all circuitry on the board is functional prior to enabling the drive. The board will only be disabled momentarily, and will quickly enable upon power up.

B.1.1 Overload

Verify that the minimum inductance requirement is met. If the inductance is too low it could appear like a short circuit to the drive and thus it might cause the short circuit fault to trip.

Excessive heating of the drive and motor is also characteristic of the minimum inductance requirement not being met. See drive datasheet for minimum inductance requirements.

B.1.2 Current Limiting

Most analog servo drives incorporate a “fold-back” circuit for protection against over-current. This “fold-back” circuit uses an approximate “ I^2t ” algorithm to protect the drive. (see “[Non-Foldback Current Limiting](#)” on page 61 for S-Series and Direct PWM drives current limiting description)

- Maximum peak current output level can be sustained for about 2 seconds.
- To actually achieve maximum peak current output for 2 seconds requires the current command to fully swing from peak in one direction to the other.

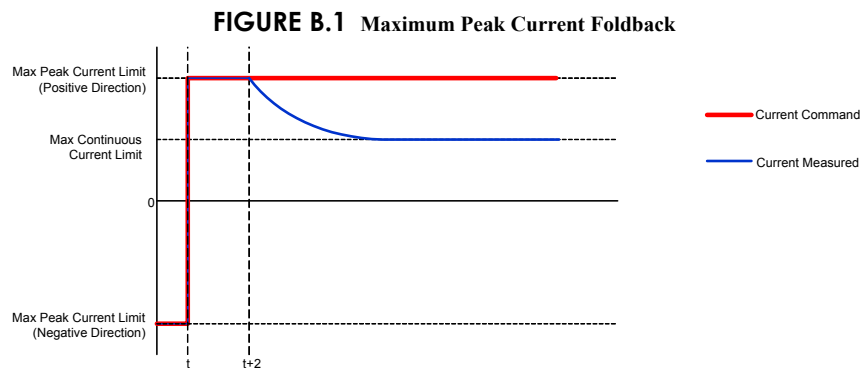

Caution

Sustained maximum current demand, when switching between positive and negative maximum current without allowing sufficient time for fold-back, will result in drive damage. Drive RMS current should be below the continuous current rating!

- For most applications, it’s a rare occurrence to fully swing from peak in one direction to the other. It is more likely the drive will be commanded from zero to max peak current. Under this condition, the drive will only sustain the maximum peak current for about one second.

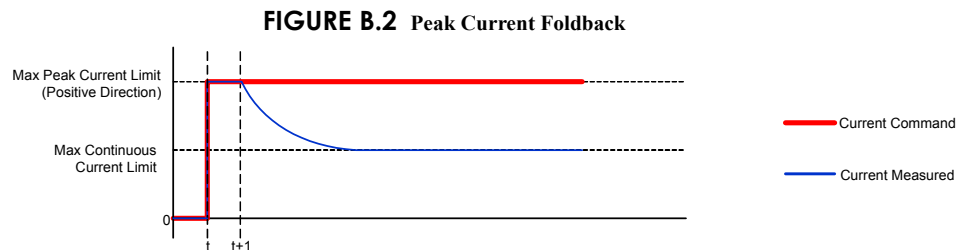

- Commanding maximum peak current output starting from above zero command will also yield reduced peak current output time.

- When commanding output current less than the max peak limit, but more than the max continuous limit, the current output can be sustained for a longer time period than a maximum peak command before folding back.

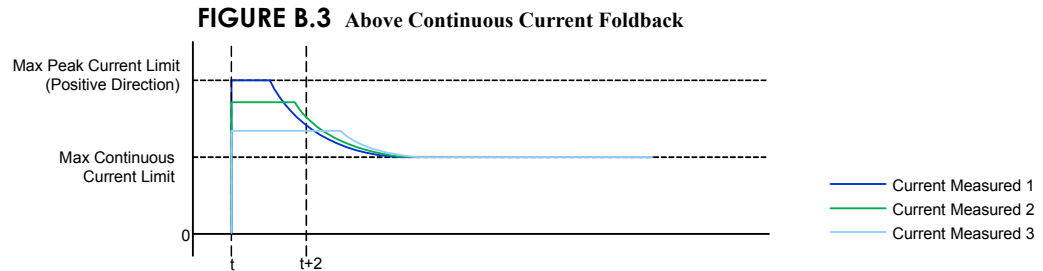

- The closer the commanded current is to the peak current limit, the shorter the peak output time will be.
- Any command at or below the maximum continuous current limit can be achieved for as long as there are no fault conditions present.
- When the drive is configured for any of the velocity modes, the user is no longer in direct control of the current output. The current commands will be determined by the velocity loop. Though internally the current loop still functions like it is described above, it will do only what is necessary to meet the velocity demand. The current output depends on:
 - How tight the velocity loop is tuned
 - The load characteristics
 - The speed the motor is already turning
 - Magnitude and slope of velocity step

Non-Foldback Current Limiting On S-Series and Direct PWM ("BD" and "DD") drives, if the RMS current through any motor phase rises above the maximum continuous current value, the over current fault output pin will trigger a fault state, and the drive will be disabled until the RMS current value has returned to a value within the acceptable operating range. Typically this results in the drive output rapidly switching on and off (several 100 Hz) until the command signal is reduced to a value below the continuous current rating of the drive.

B.1.3 Motor Problems

A motor run-away condition is when the motor spins rapidly with no control from the command input. The most likely cause of this error comes from having the feedback element connected for positive feedback. This can be solved by changing the order that the feedback element lines are connected to the drive, or changing the feedback polarity switch on the DIP switch bank to the opposite setting.

Another common motor issue for brushless motors with Hall Sensor commutation is when the motor spins faster in one direction than in the other for the same velocity command in the opposite direction. This is typically caused by improper commutation, usually because the motor power wires are connected in the wrong order with respect to the Hall Sensor wiring. Try all six combinations of connecting the motor power wires to the drive to find the correct commutation order. The proper combination of motor wires will yield smooth motion and identical speeds in both directions. Improper combinations will cause jerky motion, slow movement in one direction, and/or audible noise. As a final verification that the commutation

is correct, use the Velocity Monitor Output pin to measure motor speed in both directions . This can also be caused by invalid Hall phasing. Check to see if the drive is set for 120- or 60-degree phasing, and verify that the drive DIP switch setting corresponds to the Hall phasing used on the motor. See “Hall Sensors” on page 12 for more information.

For a brushless drive, if the opposite motor direction is desired for a given command input, interchange Hall 1 and Hall 3, then Motor A and Motor B.

B.1.4 Causes of Erratic Operation

- Improper grounding (i.e. drive signal ground is not connected to source signal ground).
- Noisy command signal. Check for system ground loops.
- Mechanical backlash, dead-band, slippage, etc.
- Noisy inhibit input line.
- Excessive voltage spikes on bus.

B.2 Technical Support

For help from the manufacturer regarding drive set-up or operating problems, please gather the following information.

B.2.1 Product Label Description

The following is a typical example of a product label as it is found on the drive:

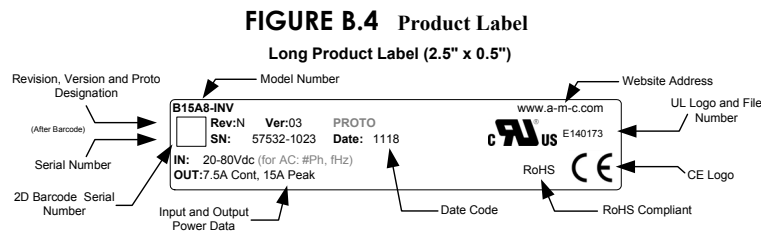

1. **Model Number:** This is the main product identifier. The model number can have a suffix designating a change from the base model.
2. **Revision Letter:** Product revision level letter ('A' is the earliest release from any model).
3. **Version:** The version number is used to track minor product upgrades with the same model number and revision letter ('01' is the earliest release of any revision).
4. **Proto Designation:** When included, indicates that the model is a prototype unit and model number will also begin with an 'X' designator.
5. **Serial Number:** The serial number consists of a 5-digit lot number followed by a 4-digit sequence number. Each product is assigned a unique serial number to track product life cycle history.
6. **Date Code:** The date code is a 4-digit number signifying the year and week of manufacture. The first two digits designate the year and the second two digits designate the week (e.g. the drive label shown would have been built in the year 2011 during the 18th week).

7. Input and Output Power Data: Includes basic power parameters of the product.
8. General Information: Displays applicable agency approvals, UL file reference number, and compliance approvals. More complete product information is available by following the listed website.

B.2.2 Drive Model Information

- DC bus voltage and range
- Motor type (brushed, brushless, AC induction)
- Motor characteristics (inductance, torque constant, winding resistance, etc.)
- Position of all DIP switches
- Length and make-up of all wiring and cables
- If brushless, include Hall sensor information
- Type of controller and full description of feedback devices
- Description of problem: instability, run-away, noise, over/under shoot, etc.
- Complete part number and serial number of the product. Original purchase order is helpful, but not necessary

B.3 Warranty Returns and Factory Help

Seller warrants that all items will be delivered free from defects in material and workmanship and in conformance with contractual requirements. The Seller makes no other warranties, express or implied and specifically NO WARRANTY OF MERCHANTABILITY OR FITNESS FOR A PARTICULAR PURPOSE. The Seller's exclusive liability for breach of warranty shall be limited to repairing or replacing at the Seller's option items returned to Seller's plant at Buyer's expense within one year of the date of delivery. The Seller's liability on any claim of any kind, including negligence, for loss or damage arising out of, connected with or resulting from this order, or from the performance or breach thereof or from the manufacture, sale, delivery, resale, repair or use of any item or services covered by or furnished under this order shall in no case exceed the price allocable to the item or service or part thereof which gives rise to the claim and in the event Seller fails to manufacture or deliver items other than standard products that appear in Seller's catalog, Seller's exclusive liability and Buyer's exclusive remedy shall be release of the Buyer from the obligation to pay the purchase price. IN NO EVENT SHALL THE SELLER BE LIABLE FOR SPECIAL OR CONSEQUENTIAL DAMAGES. Buyer will take all appropriate measures to advise users and operators of the products delivered hereunder of all potential dangers to persons or property, which may be occasioned by such use. Buyer will indemnify and hold Seller harmless from all claims of any kind for injuries to persons and property arising from use of the products delivered hereunder. Buyer will, at its sole cost, carry liability insurance adequate to protect Buyer and Seller against such claims.

All returns (warranty or non-warranty) require that you first obtain a Return Material Authorization (RMA) number from the factory. Request an RMA number by:

web	www.a-m-c.com/download/form/form_rma.html
telephone	(805) 389-1935
fax	(805) 389-1165

Symbols

±10V Analog Command	10
±10V Analog Input Wiring	36

A

AC Power Supplies	34
AC Supply Frequency	9
AC Supply Voltage Range	9
Adjustable Accel and Decel	44
Agency Compliances	ii
Altitude	26
Analog Position Loop Mode	16
Analog Position Loop Tuning	53
Attention Symbols	iii

B

Baseplate Temperature Range	26
Brushed ±10V Analog DC Drives	5
Brushed AC Supply Drives	5
Brushed PWM Input DC Drives	5
Brushed Servo Drives	7
Brushless ±10V Analog DC Drives	5
Brushless AC Supply Drives	5
Brushless PWM Input DC Drives	5
Brushless Servo Drives	7
Brushless Servo System	8
Bus Fuse	9

C

Capacitive Interference Coupling	31
CE-EMC Wiring Requirements	28
Central Point Grounding	30
Command Inputs	10
Commutation Sequence Table	13, 48
Company Website	ii
Continuous Current Limit Pin	41
Continuous Regeneration	25
Controller Chassis	30
Controller-based Commutation	8
Crimp Tool	31
Current (Torque) Mode	14
Current Limit Potentiometer	43
Current Limiting	46, 60
Current Loop Gain	50
Current Loop Integrator	52
Current Monitor Output	40

Current Reference Output	41
Custom Models	5

D

Daisy Chains	33
DC Bus Over Voltage Limit	9
DC Power Supplies	33
DC Power Supply Wiring	33
DC Supply Voltage Range	9
DIP Switch Settings	44
Drive Case Grounding	30
Drive Datasheet	4
Drive Set-up Instructions	47–49
Duty Cycle Mode	14
Dwell Time	18

E

Electromagnetic Interference	31
Encoder Velocity Mode	15
Environmental Specifications	26
Error Signal	11
External Filter Card	19

F

FAC Drive Models	34
Fault Conditions	58–60
Fault Output	42
Feedback Polarity	11
Feedback Specifications	11–13
Feedback Wiring	34–36
Fold-back	60
Frequency Factor	25

G

Ground Loops	30, 32
Grounding	30

H

Hall Sensors	
Feedback	12
Wiring	35
Hall Velocity Mode	15
Humidity	26

I

Impedance	31
-----------------	----

Incremental Encoder

Feedback	11
Wiring	35
Inhibit Input	41, 59
Input Reference Wiring	36–39
Interference Coupling	31
Internal Bus Capacitance	9
Internal Shunt Resistance	9
Internal Shunt Resistor	
Power Rating	9
Turn-on Voltage	9
Invalid Hall Commutation	59
IR Compensation Mode	16
IR Feedback Loop Tuning	52
Isolated Power Supply	22
Isolation	22

L

Linear Motor Equation	18
Lock-out/tag-out Procedures	1
Loop Gain Potentiometer	43
Low Voltage Power Outputs	42
LVD Requirements	27

M

Magnetic Interference Coupling	31
Max. Continuous Output Current	9
Max. Peak Output Current	9
Max. Power Dissipation at Continuous	
Current	9
Mechanical Shock	26
Minimum Load Inductance	9
Model Mask	4
Modes of Operation	14–16
Analog Position Loop	16
Current (Torque)	14
Duty Cycle (Open Loop)	14
Encoder Velocity	15
Hall Velocity	15
IR Compensation	16
Tachometer Velocity	15
Voltage Mode	16
Motion Control System	6
Motor "Run-Away"	11
Motor Back-EMF Voltage	19
Motor Chassis	30
Motor Current	18, 20

Motor Current Frequency	19	Power Supply Wiring	32	T	
Motor Force	19	Power-on Reset	59	Tachometer	
Motor Inductance	3, 19	Product Label	62	Feedback	13
Overload	59	Products Covered	4	Velocity Mode	15
Motor Problems	61	Protective Earth	30	Wiring	36
Motor Resistance	19	PWM and Direction Command	10	Technical Support	62
Motor Run-Away	61	PWM and Direction Input Wiring	37	Test Points (Pots)	43
Motor Torque Constant	18	PWM Current Control Circuit	6	Test/Offset Potentiometer	43
Motor Voltage	18, 20	R		Three Phase Servo Drives	7
Motor Wiring	32	REF IN, -	36	Three-Phase AC Supply	34
Mounting Options	39	REF IN, +	36	Through-hole Components	54
Move Profile	17	Reference Gain Potentiometer	43	Torque	18
Multiple Power Supply Wiring	33	Regeneration	23	Trademarks	ii
N		Continuous	25	Troubleshooting	58–63
Negative Feedback	11	Returns	63	Tuning	
Noise	31	Revision History	iii	Procedure	49–53
Nominal Power Supply Voltage	20	RMS Torque	18	Through-Hole Components	54–57
O		S		Twisted Pair Wires	31
Overload	59	Safety	1–3	U	
Over-Temperature	58	Scaling Factor	15	Under-Voltage Shutdown	59
Over-Voltage Shutdown	58	Selection and Sizing	17–26	V	
P		Servo Drive Theory	6–8	Velocity Loop Tuning	52
Part Numbering Structure	4	Shielding	30, 31	Velocity Monitor Output	42
PE Ground	30	Shock/Vibration	26	Velocity Scaling Factor	42
Peak Current Fold-back	60	Short Circuit Fault	59	Vibration	26
Peak Torque	18	Shunt Fuse	9	Voltage Drop Interference	31
Pin Functions	40–42	Shunt Regulator	21, 23	Voltage Loop Tuning	52
Positive Feedback	11	Signal Ground	30	Voltage Mode	16
Potentiometer Functions	43	Single Phase Servo Drives	7	Voltage Ripple	25
Potentiometer Test Points	43	Sinusoidal Command	10	W	
Power Ground	30	Sinusoidal Input AC Supply Drives	5	Warning Symbols	iii
Power Outputs, Low Voltage	42	Sinusoidal Input DC Drives	5	Warranty Info	63
Power Stage Specifications	9	Sinusoidal Input Wiring	39	Warranty Returns	63
Power Supply Capacitance	2, 25, 32	Standard Drive Models	5	Wire Diameter	31
Power Supply Chassis	30	Switch Functions	44	Wire Gauge	31
Power Supply Current	21	Switching Frequency	9	Wiring	31–39
Power Supply Output Current	20, 25	System Requirements	17–26		
		System Voltage Requirement	18		

Analog Drives Product Family
Hardware Installation Manual
MNALHWIN-04



3805 Calle Tecate • Camarillo, CA 93012-5068
Tel: (805) 389-1935 Fax: (805) 389-1165 www.a-m-c.com